

# TRANSDUCERIZED FIXTURED NUTRUNNER



**ESTIC**

With us, the Future

**ESTIC CORPORATION**

[www.estic.co.jp](http://www.estic.co.jp)

## Chennai Branch Contact Details



OKAYA & CO India Private Limited

PIC : Mahendran P

Mobile: +91 7339511454/99990332853

E-mail: [mahendran@okayaindia.com](mailto:mahendran@okayaindia.com)

Web: [www.okaya.co.jp/en](http://www.okaya.co.jp/en)

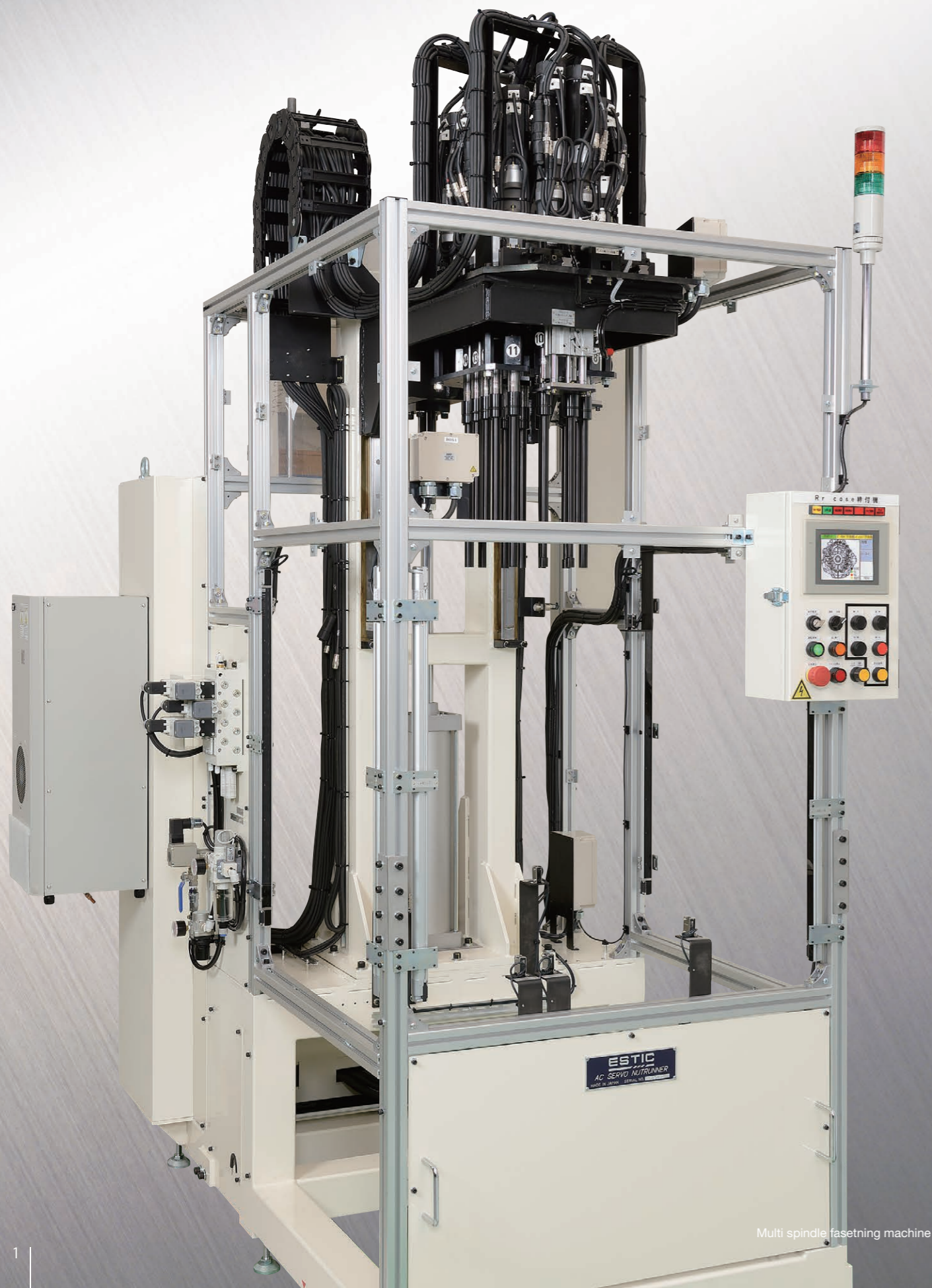

Multi spindle fastening machine

## High performance, high reliability Fixtured Nutrunner System

ESTIC's nutrunner system realizes the highest level of accuracy, motor responsiveness, durability, and is suitable for various thread fastening operations which require traceability.

- Self-diagnosis function on each fastening
- Double structure torque monitoring

Torque is not only monitored by the torque sensor, but also by current. Fastening operations are monitored, and crucial data, such as torque, angle and time is recorded.

Management Software, and Touch Screens are available for easy setup and operation. User friendly software allows operators to program various parameters such as fastening programs, as well as collect fastening results and torque curve data.

Fastening results with VIN information produced and reported by Fastening systems, calibrated with the national standard traceable method

Fastening result data and torque curve data are available and stored for traceability and analysis purposes.

High Reliability

Traceability

Durability

Extremely high durability to maximize the operation time

Equipped with high durability reducer gear and resolver.

Finest fastening accuracy

State of the art servo motor and feedback control by high speed process realize high dynamic accuracy of  $3\sigma/\bar{X} \leq 2\%$  (at Full Scale).

Stable thread fastening

Leak of torque typically seen on soft joints can be minimized by using the Dynamic Stall function and the Sequenced fastening program.

Networking Extensibility

Various networking options are available such as Ethernet, and Fieldbus

Possible to communicate with PLC, Factory automation system by complying with various types of communication protocols.

Monitoring functions to keep watch over fastening quality

Torque rate function monitors increase ratio of torque and angle.

By monitoring the increasing ratio of torque and angle, the system judges abnormal fastenings, and realizes certainty of fastening process.

The innovative component for bolt and nut tightening process

Easy operation

Nutrunner systems can be configured in many combinations to fit a wide array of requirements. Allowing for flexible system building and I/O connection with PLC, allowing an external device to control the fastening sequence and data handling.

## SYSTEM 1 MASTER CONTROL SYSTEM

Nutrunner systems utilize digital communication protocols such as Ethernet and Fieldbus as well various user supported functions such as HMI, and USB flash drives in order to maximize control and productivity in multi-spindle applications.

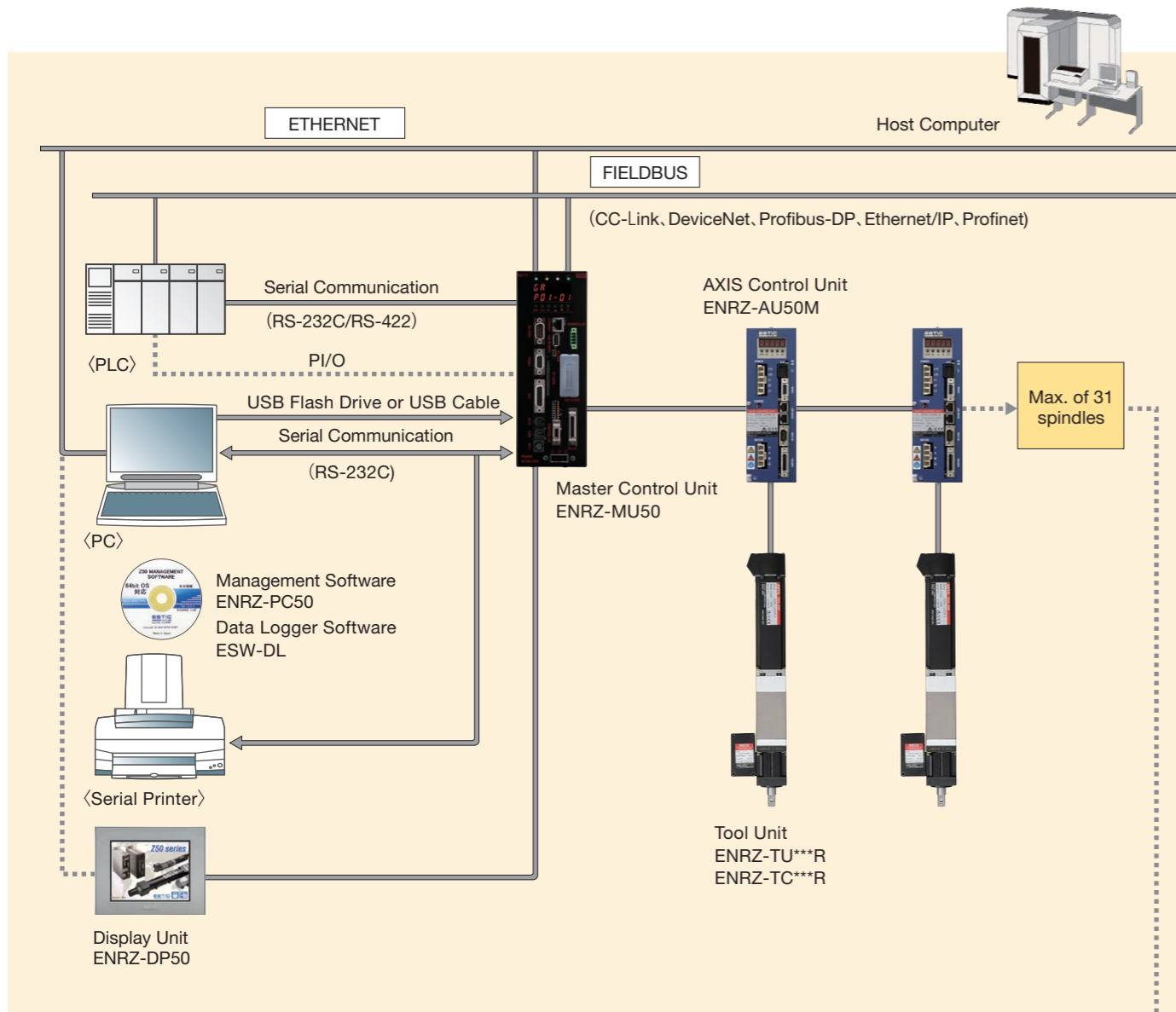

## SYSTEM 2 FASTENING AND PRESS INTEGRATED SYSTEM

Assembly machines are not limited to thread fastening but also allow for the integration of servo press machines that are controlled by the same Master Control Unit. This allows for a combination of Nutrunner and Servo Press units working together to create a flexible assembly system.

\*Please inquire with our sales office for more details.

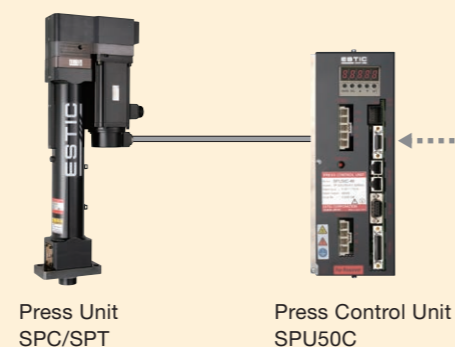

## SYSTEM 3 AXIS CONTROL SYSTEM

A simple system in which the PLC and Controller are connected by I/O.

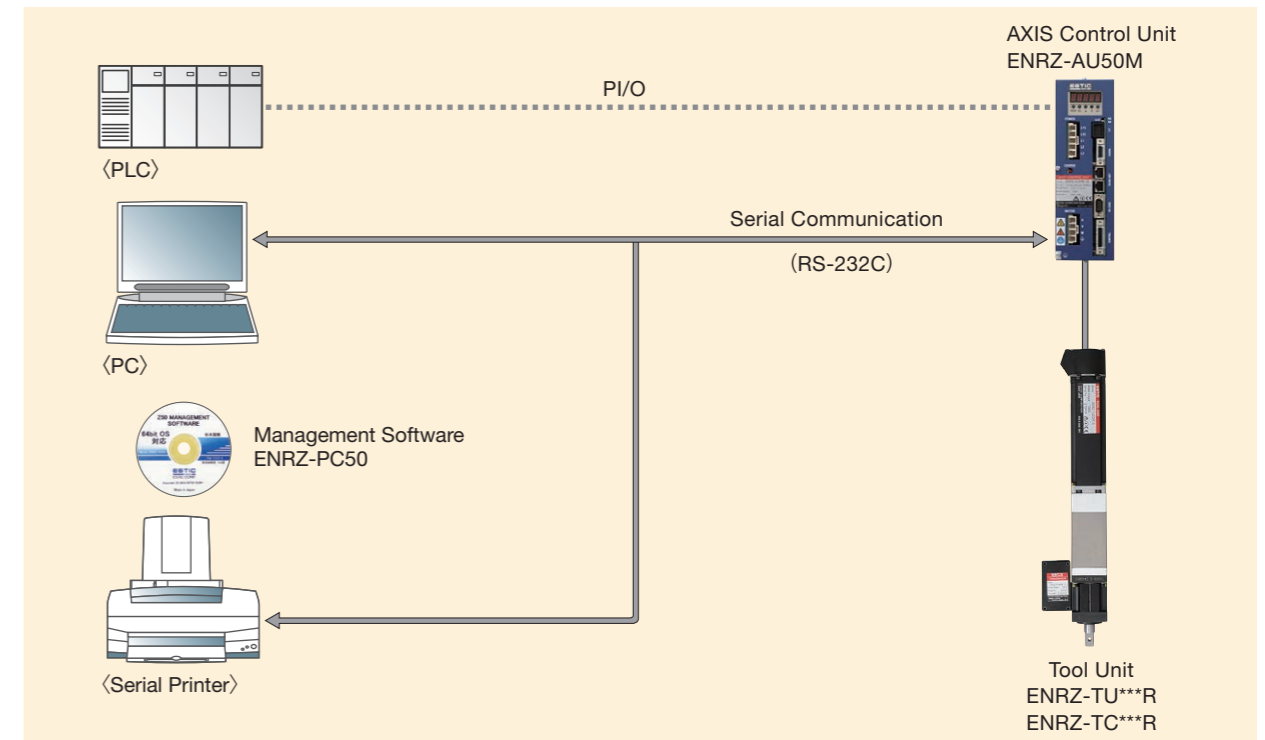

## SYSTEM 4 AXIS Control Multi Spindle System

A multi-Spindle system in which the PLC and each controller is connected by I/O. The fastening program can be uploaded/downloaded through the Master AXIS Control Unit.

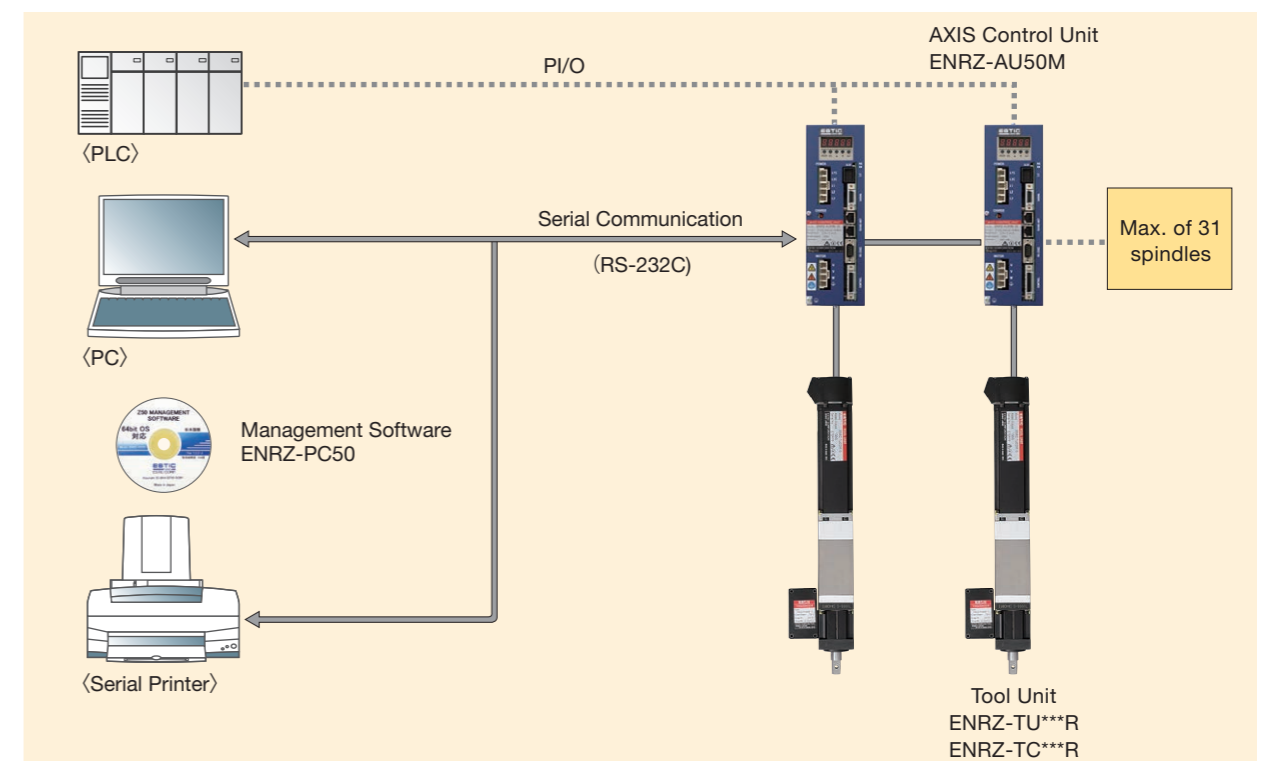

# Durable, high speed, high accuracy tool unit in a small form factor.

- ▶ Highly accurate torque detection is realized by 8 strain gauge type torque transducer with noise cancellation function.
- ▶ A wide torque range from 0.5Nm up to 3000Nm is covered.
- ▶ Suitable for various applications with Straight type, Offset type, Bent type, Angle head type.



## Tool Unit Basic Specifications

Model	Straight type	ENRZ-TU0R5R-S	ENRZ-TU001R-S	ENRZ-TC002R-S	ENRZ-TU003R-S	ENRZ-TC004R-S	ENRZ-TU004R-S
	Offset type	—	ENRZ-TU001R-O	ENRZ-TC002R-O	ENRZ-TU003R-O	ENRZ-TC004R-O	—
Rated Torque (Nm)		5	10	20	30	40	40
Applicable Torque Range (Nm)		0.5-4.5	1-9	2-18	3-27	4-36	4-36
Max. Speed (rpm)		3940	1714	1960	655	1120	2050
Torque converter	Strain gauge type torque transducer with amplifier built-in						
Torque Display Resolution (Nm)		0.01	0.01	0.01	0.01	0.01	0.01
Angle detector	Resolver						
Angle Display Resolution (deg)		0.1					
Dynamic Torque Accuracy	$3\sigma/\bar{X} \leq 2\%$ (FS)						
Weight (Kg)		1.7	1.9(2.3)	1.8(2.2)	1.9(2.3)	1.8(2.2)	3.8
Corresponding Controller type		ENRZ-AU50M-10		ENRZ-AU50M-20	ENRZ-AU50M-10	ENRZ-AU50M-20	

\* Weight in ( ) is for offset type.

## Model

# ENRZ-TU 001R-S

Tool Unit Model

TU : Standard tools TC : High speed Light-weight tools

Rated Torque

0R5 : 5 N·m	008 : 80 N·m	060 : 600 N·m
001 : 10 N·m	013 : 130 N·m	080 : 800 N·m
002 : 20 N·m	020 : 200 N·m	120 : 1200 N·m
003 : 30 N·m	040 : 400 N·m	150 : 1500 N·m
004 : 40 N·m	050 : 500 N·m	300 : 3000 N·m

Tool Type

S : Straight type ST : Straight Bent type  
O : Offset type OP : Offset Bent type

## Tool models

### Straight type

Compact, high performance tool unit.  
Small high power servo motor developed for the Nutrunner with a built-in precision torque transducer.

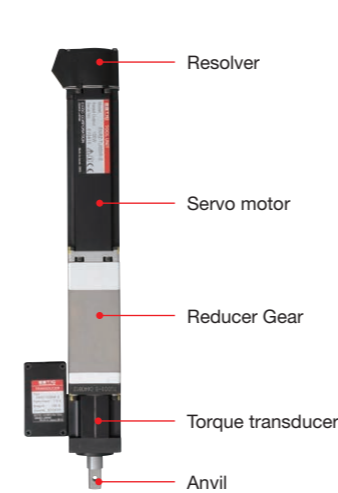

### Offset type

Offset gears are built-in for narrow pitch, multi spindle applications

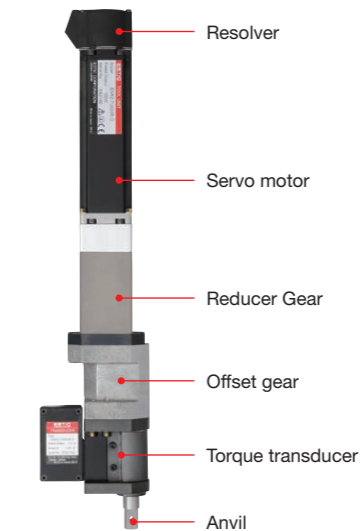

### Bent type

Built-in gear train reduces height for applications with height limitations.

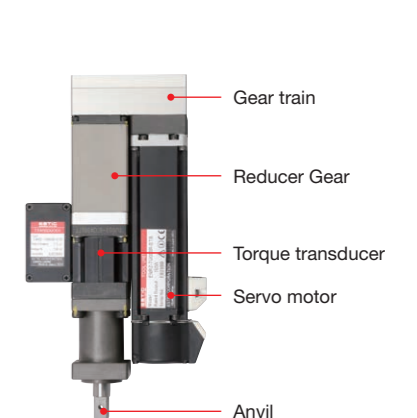

Straight tool	Offset tool
ENRZ-TU001R-S	ENRZ-TU001R-O
ENRZ-TU003R-S	ENRZ-TU003R-O
ENRZ-TU008R-S	ENRZ-TU008R-O
ENRZ-TU013R-S	ENRZ-TU013R-O
ENRZ-TU020R-S	ENRZ-TU020R-O
ENRZ-TU040R-S	
ENRZ-TU120R-S	

\* Max. tightening capacity of Bent type is 80% of Straight/Offset type.

ENRZ-TU008R-S	ENRZ-TU013R-S	ENRZ-TU020R-S	ENRZ-TU040R-S	ENRZ-TU050R-S	ENRZ-TU060R-S	ENRZ-TU080R-S	ENRZ-TU120R-S	ENRZ-TU150R-S	ENRZ-TU300R-S
ENRZ-TU008R-O	ENRZ-TU013R-O	ENRZ-TU020R-O	ENRZ-TU040R-O	—	—	—	—	—	—
80	130	200	400	500	600	800	1200	1500	3000
8-72	13-117	20-180	40-360	50-450	60-540	80-720	120-1080	150-1350	300-2700
1000	700	407	207	405	158	116	117	60	39
Strain gauge type torque transducer with amplifier built-in									
0.01	0.01	0.1	0.1	0.1	0.1	0.1	0.1	0.1	1
Resolver									
0.1									
$3\sigma/\bar{X} \leq 2\%$ (FS)									
4.2(4.7)	4.2(5.2)	5.5(6.5)	6.3(9.3)	11.3	12	12	14.3	32.5	22.6
ENRZ-AU50M-20				ENRZ-AU50M-5K2	ENRZ-AU50M-40		ENRZ-AU50M-5K2	ENRZ-AU50M-2K	ENRZ-AU50M-5K2

**Straight type** ENRZ-TU0R5R-S / ENRZ-TU001R-S / ENRZ-TU003R-S / ENRZ-TU050R-S / ENRZ-TU060R-S / ENRZ-TU080R-S / ENRZ-TU120R-S / ENRZ-TU150R-S / ENRZ-TC002R-S / ENRZ-TC004R-S

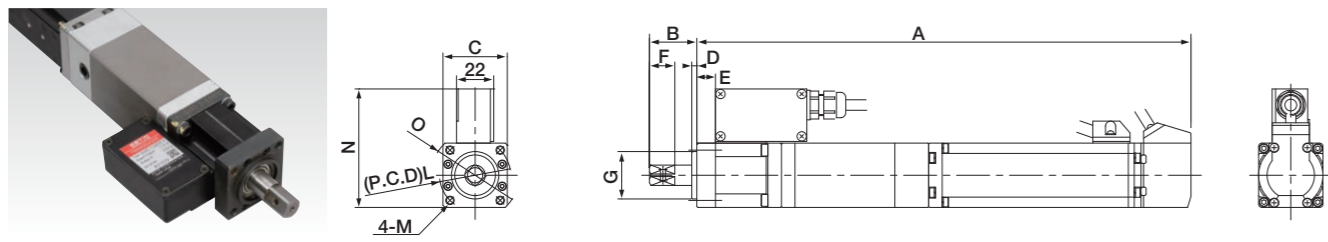

**Straight type** ENRZ-TU004R-S / ENRZ-TU008R-S / ENRZ-TU013R-S / ENRZ-TU020R-S / ENRZ-TU040R-S

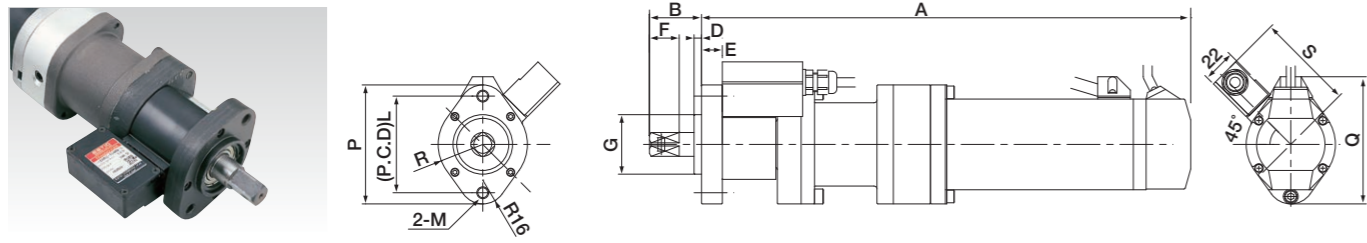

**Straight type** ENRZ-TU300R-S

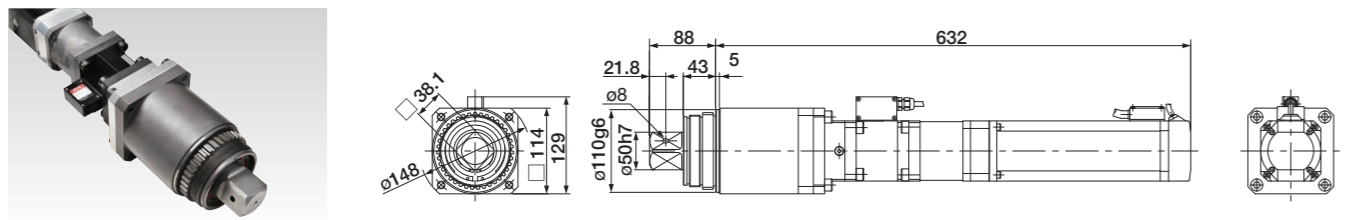

**Offset type** ENRZ-TU001R-O / ENRZ-TU003R-O / ENRZ-TC002R-O / ENRZ-TC004R-O

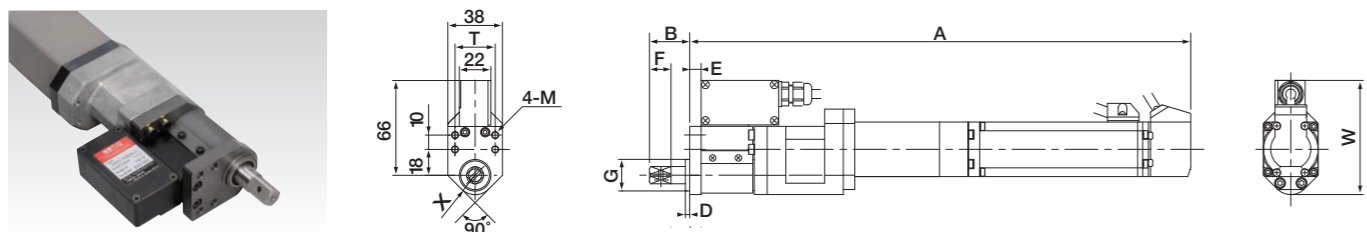

**Dimension chart**

Tool Model	A	B	C	D	E	F	G	H	I	J	K
ENRZ-TU0R5R-S	277	28	38	3	11	15	ø28g7	8	ø12h7	ø3	□ 9.5
ENRZ-TU001R-S	286	28	38	3	11	15	ø28g7	8	ø12h7	ø3	□ 9.5
ENRZ-TU001R-O	343	28	—	3	8	15	ø22g7	8	ø12h7	ø3	□ 9.5
ENRZ-TC002R-S	281.5	28	38	3	11	15	ø28g7	8	ø12h7	ø3	□ 9.5
ENRZ-TC002R-O	338.5	28	—	3	8	15	ø22g7	8	ø12h7	ø3	□ 9.5
ENRZ-TU003R-S	292	28	38	3	11	15	ø28g7	8	ø12h7	ø3	□ 9.5
ENRZ-TU003R-O	349	28	—	3	8	15	ø22g7	8	ø12h7	ø3	□ 9.5
ENRZ-TC004R-S	281.5	28	38	3	11	15	ø28g7	8	ø12h7	ø3	□ 9.5
ENRZ-TC004R-O	338.5	28	—	3	8	15	ø22g7	8	ø12h7	ø3	□ 9.5
ENRZ-TU004R-S	302.5	35	—	5	10	20	ø40g7	8	ø16h7	ø4.5	□12.7
ENRZ-TU008R-S	329	35	—	5	14	20	ø40g7	8	ø16h7	ø4.5	□12.7
ENRZ-TU008R-O	399	35	—	5	10	20	ø28g7	8	ø16h7	ø4.5	□12.7
ENRZ-TU013R-S	329	40	—	6	14	25	ø46g7	9	ø20h7	ø4.5	□15.9
ENRZ-TU013R-O	412	40	—	5	10	25	ø32g7	9	ø20h7	ø4.5	□15.9
ENRZ-TU020R-S	384	40	—	6	14	25	ø46g7	9	ø25h7	ø4.5	□19.0
ENRZ-TU020R-O	468	40	—	5	10	25	ø40g7	9	ø24h7	ø4.5	□19.0
ENRZ-TU040R-S	398	55	—	7	15	30	ø60g7	14.5	ø30h7	ø6.3	□25.4
ENRZ-TU040R-O	525.5	53	—	5	15	30	ø48g7	14.5	ø30h7	ø6.3	□25.4
ENRZ-TU050R-S	460	55	80	7	15	30	ø55g7	14.5	ø32h7	ø6.3	□25.4
ENRZ-TU060R-S	446	55	80	7	15	30	ø55g7	14.5	ø32h7	ø6.3	□25.4
ENRZ-TU080R-S	446	55	80	7	15	30	ø60g7	14.5	ø40h7	ø6.3	□31.8
ENRZ-TU120R-S	543	55	80	7	15	30	ø60g7	14.5	ø39.72h7	ø6.3	□31.8
ENRZ-TU150R-S	486	80	130	10	20	50	ø110g7	25	ø50h7	ø9	□38.1

**Offset type** ENRZ-TU008R-O / ENRZ-TU013R-O / ENRZ-TU020R-O / ENRZ-TU040R-O

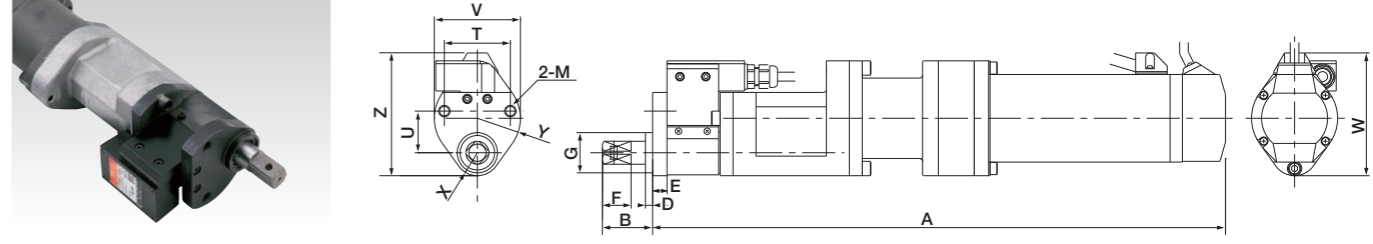

**Bent type**

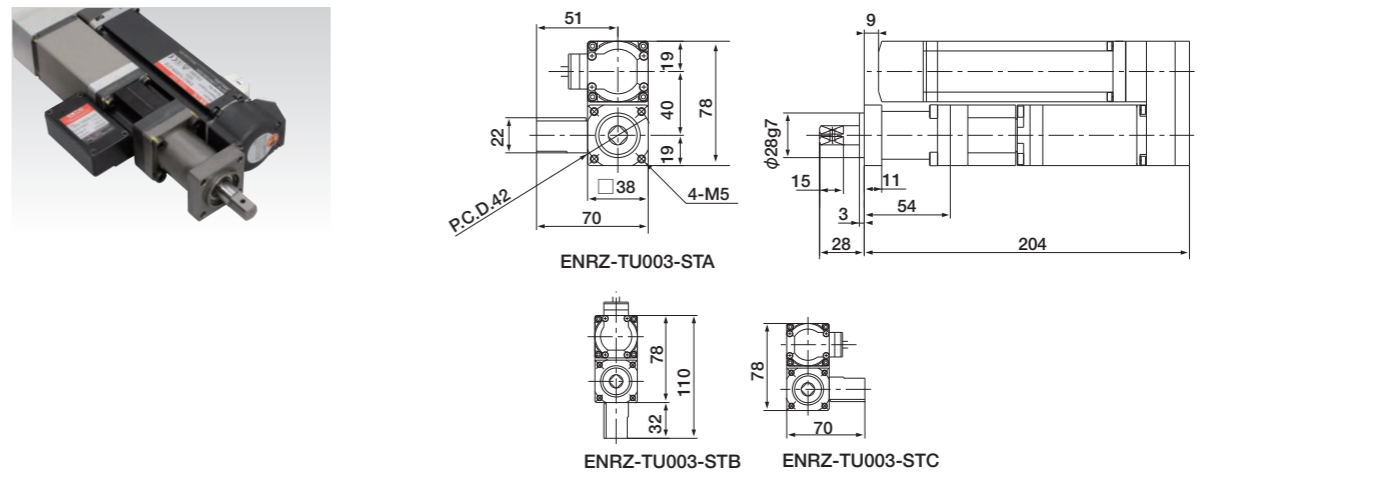

\* Tool model is different depending on the direction of the transducer. Refer to CAD data (available at <https://www.estic2.com/caddata/>) for the details.

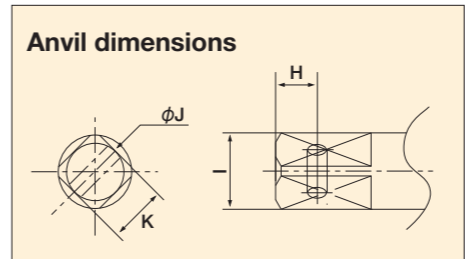

L	M	N	O	P	Q	R	S	T	U	V	W	X	Y	Z
42	M 5	70	ø52	—	—	—	—	—	—	—	—	—	—	—
42	M 5	70	ø52	—	—	—	—	—	—	—	—	—	—	—
—	M 5	—	—	—	—	—	—	28	—	—	79.5	R13.5	—	—
42	M 5	70	ø52	—	—	—	—	—	—	—	—	—	—	—
—	M 5	—	—	—	—	—	—	28	—	—	79.5	R13.5	—	—
42	M 5	70	ø52	—	—	—	—	—	—	—	—	—	—	—
—	M 5	—	—	—	—	—	—	28	—	—	79.5	R13.5	—	—
42	M 5	70	ø52	—	—	—	—	—	—	—	—	—	—	—
—	M 5	—	—	—	—	—	—	28	—	—	79.5	R13.5	—	—
65	M 8	—	—	80	85.5	R30	65.5	—	—	—	—	—	—	—
65	M 8	—	—	80	85.5	R30	65.5	—	—	—	—	—	—	—
—	M 8	—	—	—	—	—	—	46	29	60	85.5	R16	R30	80
65	M10	—	—	80	85.5	R30	65.5	—	—	—	—	—	—	—
—	M10	—	—	—	—	—	—	44	32	60	91.5	R19	R30	86.5
65	M10	—	—	80	85.5	R30	65.5	—	—	—	—	—	—	—
—	M10	—	—	—	—	—	—	44	36.5	60	—	R23	R30	100
84	M12	—	—	100	—	R33	71	—	—	—	—	—	—	—
—	M12	—	—	—	—	—	—	46	50	66	—	R26.5	—	118.5
88	M12	112	ø110	—	—	—	—	—	—	—	—	—	—	—
88	M12	113	ø110	—	—	—	—	—	—	—	—	—	—	—
88	M12	113	ø110	—	—	—	—	—	—	—	—	—	—	—
88	M12	102	ø110	—	—	—	—	—	—	—	—	—	—	—
145	M16	180	ø170	—	—	—	—	—	—	—	—	—	—	—

\* 2D/3D CAD data is available on the website (<https://www.estic2.com/caddata/>)

## Socket Assembly

Model	Applicable tool unit	Adapter insertion angle
TNA1-SA02-30*	ENRZ-TU0R5R-S	□ 9.5
	ENRZ-TU001R-S/O	
	ENRZ-TU003R-S/O	
	ENRZ-TC002R-S/O	
	ENRZ-TC004R-S/O	
TNA1-SA05-35	ENRZ-TU004R-S ENRZ-TU008R-S/O	□ 12.7
TNA1-SA20-45C	ENRZ-TU013R-S/O	□ 15.9
TNA1-SA20-45Z	ENRZ-TU020R-S/O	□ 15.9
TNA1-SA40-70	ENRZ-TU040R-S/O	□ 25.4
	ENRZ-TU050R-S	
	ENRZ-TU060R-S	
TNA1-SA80-80	ENRZ-TU080R-S	□ 31.8
	ENRZ-TU120R-S	
ENRZ-SA150-120	ENRZ-TU150R-S	□ 38.1



\* Please consult with us when it is used for tightening above 36Nm.

## Socket Adapter

Model	Socket assembly slide - Socket slide
TNA1-AD01-01	□ 9.5—□ 9.5
TNA1-AD05-01	□ 12.7—□ 12.7
TNA1-AD05-02	□ 12.7—□ 9.5
TNA1-AD20-01	□ 15.9—□ 15.9
TNA1-AD20-02	□ 15.9—□ 12.7
TNA1-AD20-03	□ 15.9—□ 19
TNA1-AD40-01	□ 25.4—□ 25.4
TNA1-AD40-02	□ 25.4—□ 19
TNA1-AD80-01	□ 31.8—□ 31.8
TNA1-AD80-02	□ 31.8—□ 25.4
ENRZ-AD150-01	□ 38.1—□ 38.1
ENRZ-AD150-02	□ 38.1—□ 25.4

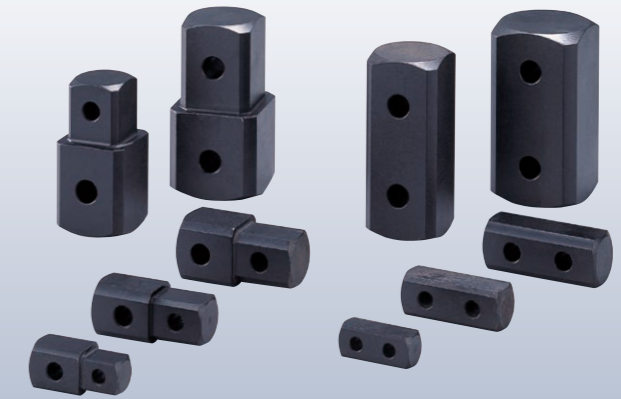

## How to mount a nutrunner

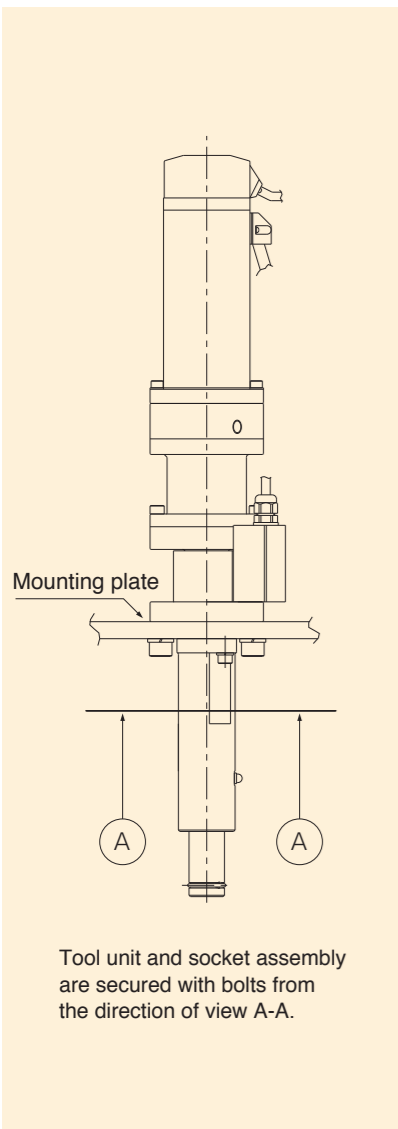

## Reference drawing for mounting a socket assembly (the arrows A to A)

TNA1-SA02-30

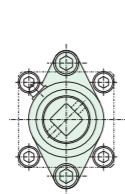

5, 10, 20, 30, 40Nm  
For Straight tool

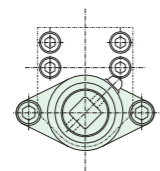

10, 20, 30, 40Nm  
For Offset tool

TNA1-SA05-35

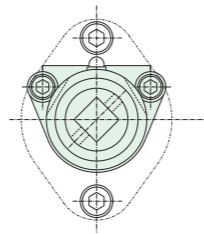

40, 80Nm  
For Straight tool

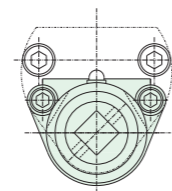

80Nm  
For Offset tool

TNA1-SA20-45C

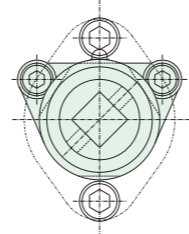

130Nm  
For Straight tool

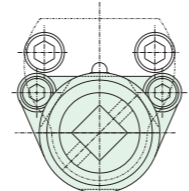

130Nm  
For Offset tool

TNA1-SA20-45Z

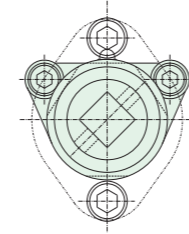

200Nm  
For Straight tool

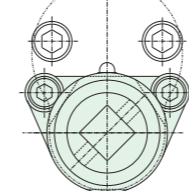

200Nm  
For Offset tool

TNA1-SA40-70

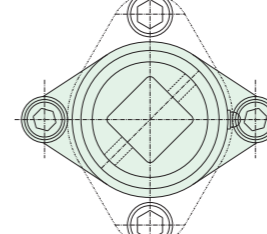

400Nm  
For Straight tool

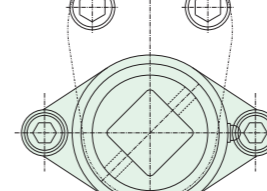

400Nm  
For Offset tool

TNA1-SA80-80

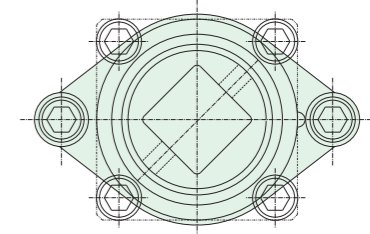

800, 1200Nm  
For Straight tool (\*1)

ENRZ-SA150-120

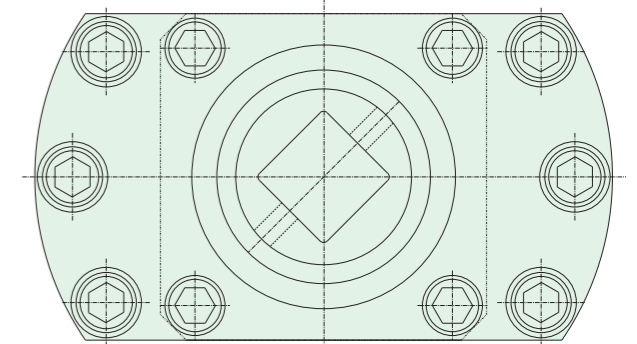

1500Nm  
For Straight tool

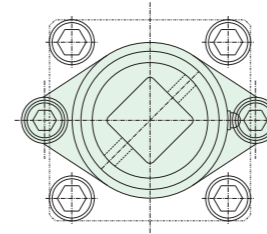

500, 600Nm  
For Straight tool

(\*1) Please design so as to have counterbore holes for the tool mounting bolts on the tool mounting plate. In addition, please design not to interfere the tool mounting bolts and the socket assembly flange.

Socket Assembly external dimensions

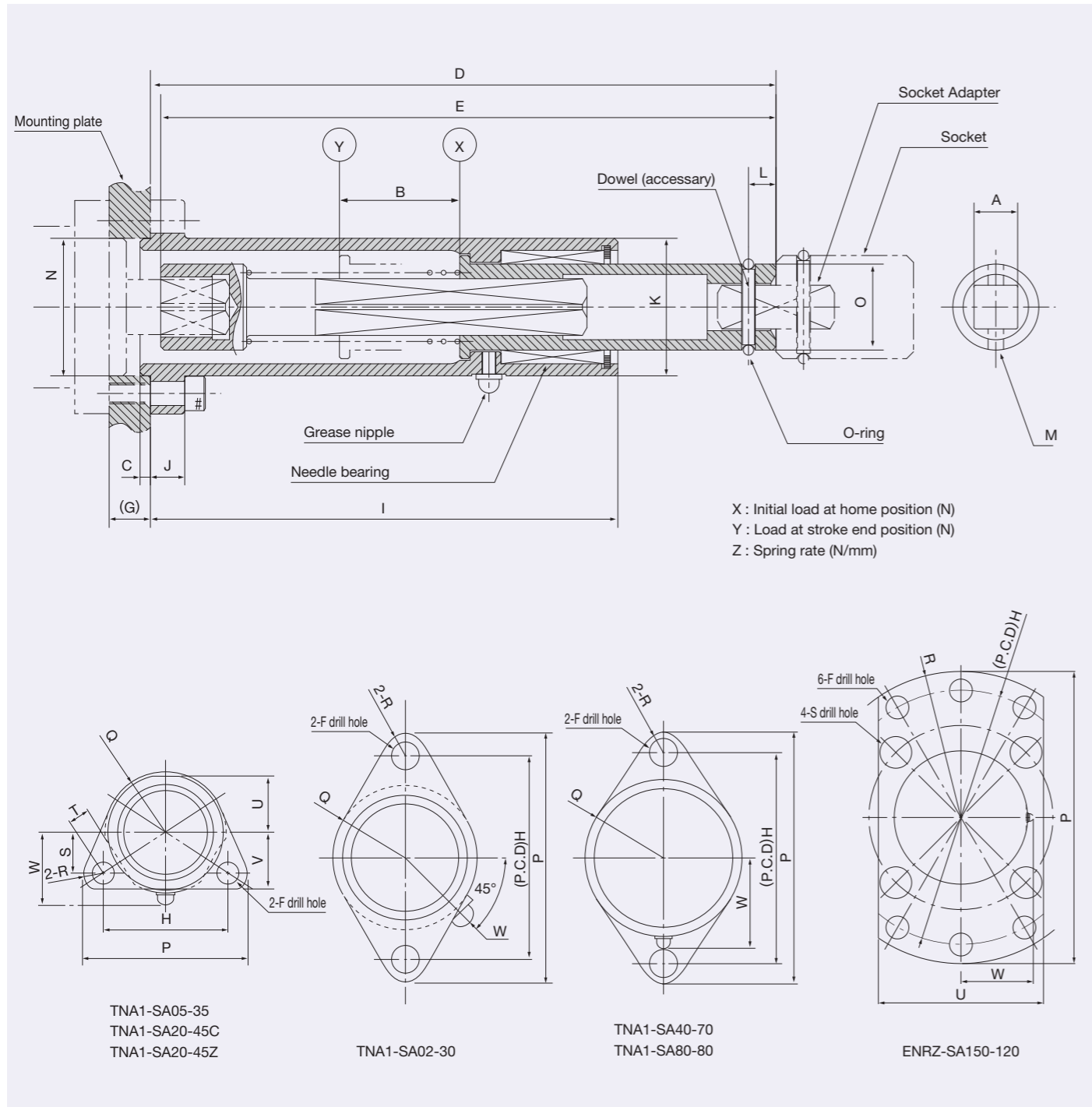

Table of dimensions for Socket Assembly

Model	A	B	C	D	E	F	G	H	I	J	K	L	M
TNA1-SA02-30	□ 9.5	30	3	155	153	φ 6.5	(12)	45	109	8	φ 30	5.5	φ4
TNA1-SA05-35	□12.7	35	3	182	179	φ 7	(12)	43	136	10	φ 40	8	φ4.5
TNA1-SA20-45C	□15.9	45	3	212	209	φ 9	(12)	50	153	12	φ 48	9	φ6
TNA1-SA20-45Z	□15.9	45	3	212	209	φ 9	(12)	50	153	12	φ 48	9	φ6
TNA1-SA40-70	□25.4	70	3	309	300	φ11	(16)	84	219	15	φ 62	15	φ7.5
TNA1-SA80-80	□31.8	80	5	340	331	φ14	(16)	108	230	16	φ 76	16.5	φ7.5
ENRZ-SA150-120	□38.1	120	6	454	449	φ18	(25)	200	294	20	φ105	19	φ9

Socket Adapter external dimensions

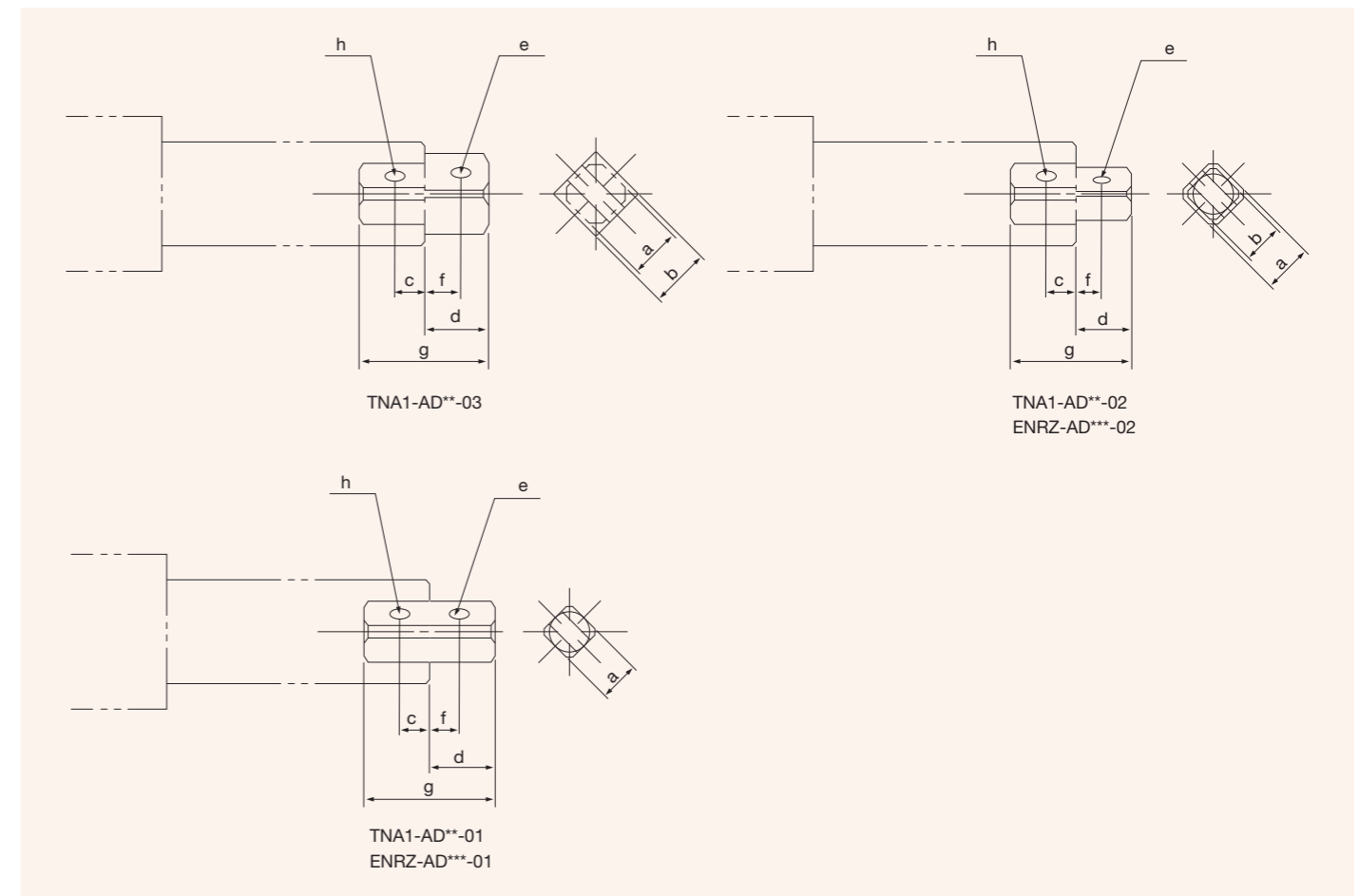

Table of dimensions for Socket Adapter

Model	a	b	c	d	e	f	g	h	Weight (g)
TNA1-AD01-01	□ 9.5	—	5.5	12	φ4	5.5	24	φ4	15
TNA1-AD05-01	□12.7	—	8	17	φ5	8	34	φ5	37
TNA1-AD05-02	□12.7	□ 9.5	8	12	φ4	5.5	29	φ5	26
TNA1-AD20-01	□15.9	—	9	20	φ6	9	40	φ6	66
TNA1-AD20-02	□15.9	□12.7	9	17	φ5	8	37	φ6	51
TNA1-AD20-03	□15.9	□19	9	20	φ6.5	11	40	φ6	82
TNA1-AD40-01	□25.4	—	15	30	φ7.5	15	60	φ7.5	272
TNA1-AD40-02	□25.4	□19	15	20	φ6	11	50	φ7.5	186
TNA1-AD80-01	□31.8	—	16.5	30	φ7.5	16.5	60	φ7.5	434
TNA1-AD80-02	□31.8	□25.4	16.5	30	φ7.5	15	60	φ7.5	354
ENRZ-AD150-01	□38.1	—	19	39	φ9	19	78	φ9	833
ENRZ-AD150-02	□38.1	□25.4	19	30	φ7.5	15	69	φ9	555

N	O	P	Q	R	S	T	U	V	W	X	Y	Z	Dowel (accessory)	O-ring	Weight (kg)
φ28g7	φ18g7	55	R15	R 5	—	—	—	—	19.5	13.5	23.2	0.323	φ3x16	P16	0.5
φ40g7	φ25g7	55	R21	R 6	13	7	21	21.5	25	14.2	25.5	0.323	φ4x20	P22	1.0
φ46g7	φ32g7	65	R24	R 7.5	16	8.5	22.5	22.5	29	18.1	34.5	0.362	φ5x25	P29	1.3
φ46g7	φ32g7	65	R24	R 7.5	16	8.5	22.5	22.5	29	18.1	34.5	0.362	φ5x25	P29	1.3
φ60g7	φ45g7	100	R31	R 8	—	—	—	—	36	27.5	43.6	0.225	φ6x40	P42	3.6
φ80g7	φ55g7	128	R42	R 10	—	—	—	—	43	47	77.4	0.362	φ6x50	P52	9.6
φ110g7	φ70g7	230	R65	R115	φ25	—	130	—	57	39.2	74.1	0.291	φ6x60	P63	16.5

\* 2D/3D CAD data is available on the website (<https://www.estic2.com/caddata/>)

Fastening strategies

1 Torque Control

This fastening method is commonly used. Fastening is stopped when a predefined target torque has been reached. Judgment is made if the peak torque is within range of the upper and lower limit. If the fastening falls within the predefined range then an OK result is produced. If the fastening exceeds or falls short of the range then an NG judgment is made. With this system total judgment is performed by measuring the upper and lower limit of fastening time, as well as upper and lower limit for torque.

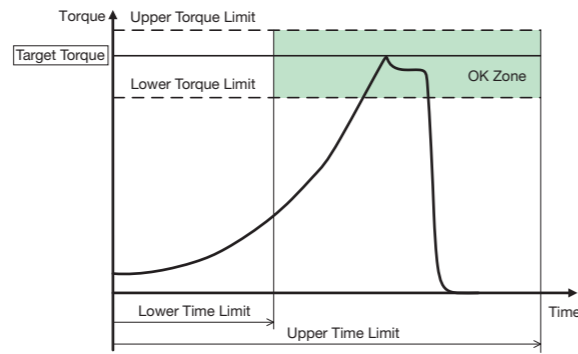

2 Torque Control Angle Monitor

Fastening is performed establishing an upper and lower limit for torque, as well as creating an upper and lower limit for angle.

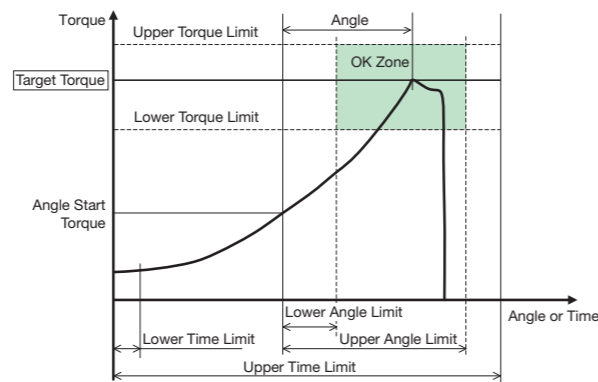

3 Angle Control

With this fastening method, fastening is performed from an angle measuring start torque until an optionally set fastening target angle has been reached. Fastening is then stopped, and judgment is made. If the angle and torque value are within the range between the set upper and lower limit, then an OK or NG (for each value) is produced.

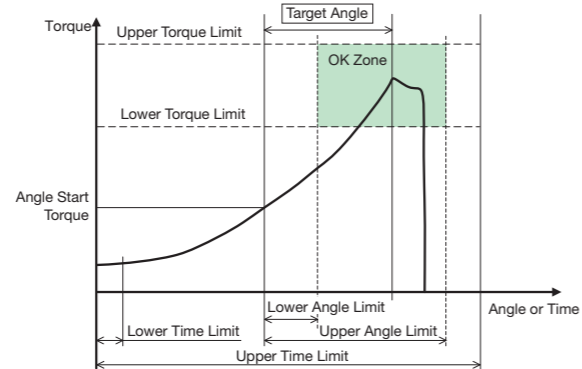

4 Torque or Angle Control

Basically, this control method is similar to the torque method angle monitor, but the stop control condition for the target is effective for the target torque and the target angle, and the output axis is stopped when one of the target values has been reached.

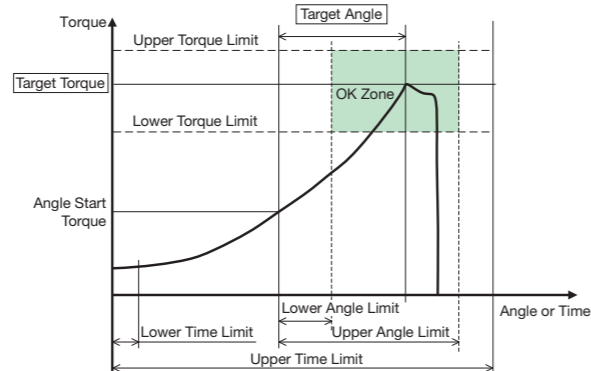

5 Torque and Angle Control

Unlike the torque or angle method, when both of the target torque and target angle is detected, the output spindle is stopped and a judgement is made. When the upper limit torque, upper limit angle or upper limit time is exceeded during execution, the step terminates due to fastening NG.

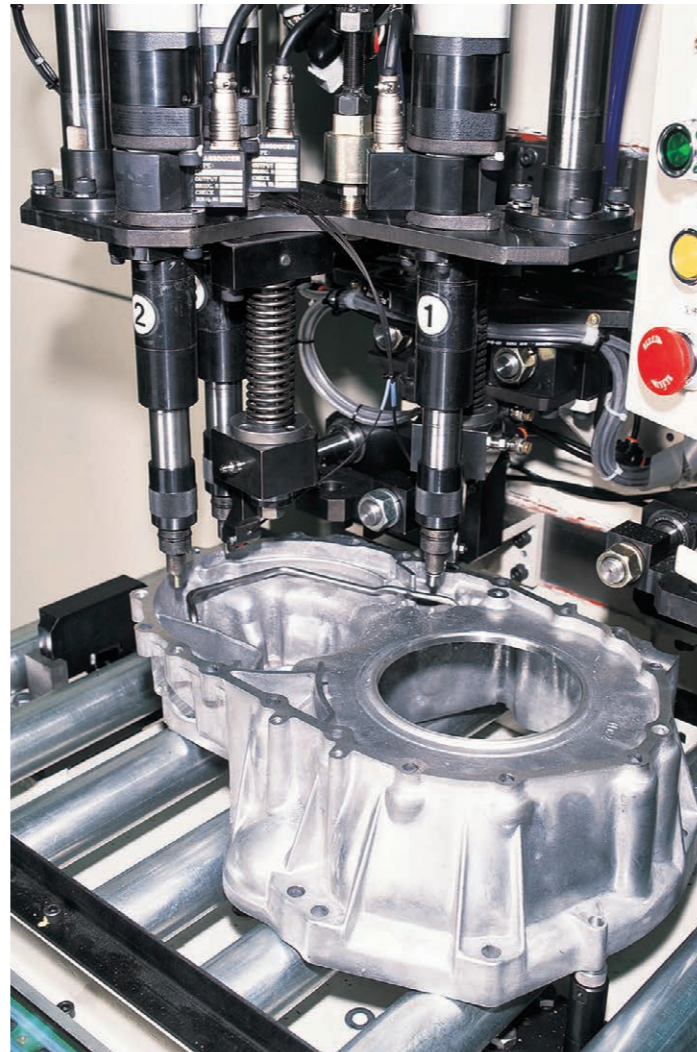

6 Yield Angle Control

This fastening method brings out the tension (clamping force) of a bolt to its greatest extent. The yield point is obtained from the torque increase rate (torque rate), fastening is performed for the set angle from this point and fastening is completed in a stable plastic region initial state.

Sampling of the angle data is started from the point at which the ANG start torque is detected. When the snug torque is detected, fastening is performed while calculating the torque rate. Additional fastening is performed for the target angle from the point at which the target torque rate is detected, and then fastening is completed.

When the lower limit angle is not reached at the completion of additional fastening after the detection of the yield point, additional fastening is performed again until the lower limit angle has been reached.

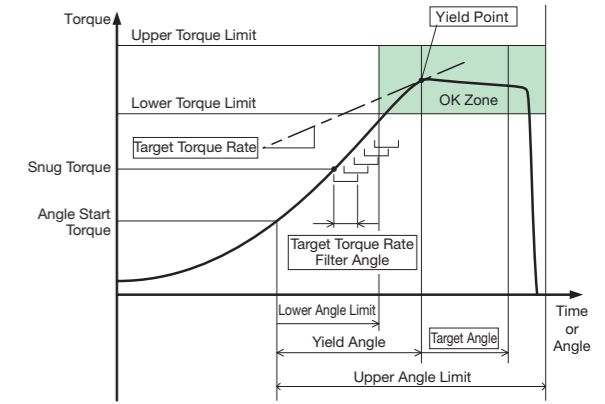

7 Yield Control

Basically, this method performs the same control as the yield angle method. In this case, when the lower limit angle is not reached at the completion of additional fastening after the detection of the yield point, additional fastening is not performed and the step terminates due to fastening NG.

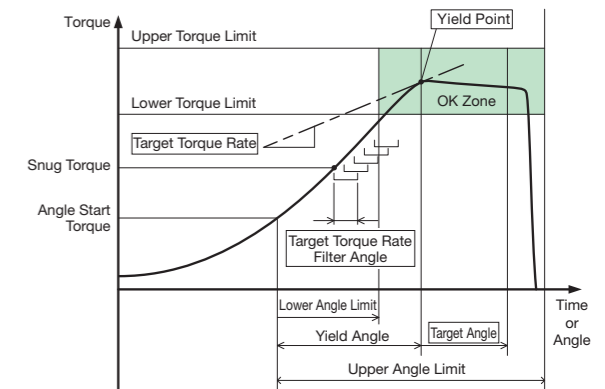

Fastening Theory

With bolt fastening, a fastening force is generated between the parts by the application of a fastening torque. With T as the fastening torque and N as the fastening force (axial force) generated between the parts. The relationship is as shown below when the part and the fastened object are within the elastic limit.

$$T = KdN \quad T = \text{Torque (Nm)} \quad N = \text{Axial Force (N)} \quad K = \text{Torque Coefficient} \quad d = \text{Nominal Bolt Diameter (m)}$$

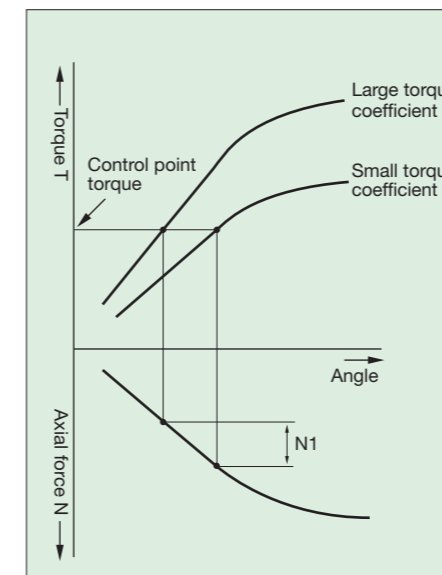

Torque Control

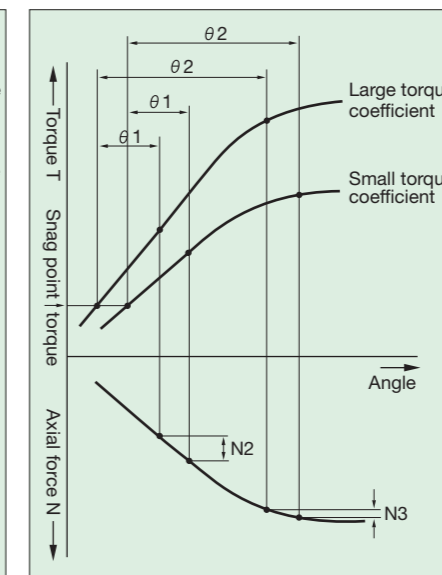

Angle Control

K changes depending on the connection state between the thread and bolt seat surface. There is considerable scatter even for bolts and tapping even when manufactured under the same conditions. As shown in the figure on the left, when fastening to the target torque T with the torque method, the axial force of the bolt shows the scatter N1 because of the difference in torque coefficient, even when the torque is constant. However, with the angle method fastening for the constant angle  $\theta_1$  from the snug point, the scatter of the axial force becomes N2, which is smaller than with the torque method. When the fastening angle is made  $\theta_2$  and fastening is performed within the elastic range of the bolt, the scatter of the axial force becomes N3, which is still smaller. Accordingly, for execution of fastening without loosening, it is necessary to select the fastening method according to the fastening conditions for the object to be fastened and the conditions at the time of product design.

This control unit was developed for a single spindle. It accomplishes high accuracy, high quality fastening with simple configuration parameters. Monitor functions required for fastening come standard, and judgment is determined by torque, angle, time, or torque rate.



## Front Panel Wiring

### Data Display

- Real time torque value indication
- Final torque indication
- System error message indication
- Setting Parameter
- Test mode
- Log mode

### Operation button

- Mode change
- Display change
- Parameter edit and set

### Power supply cable

Motor power supply and control power supply are separated

### Charge lamp

### Motor cable \*

\* The connection port of ENRZ-AU50M-5K2 is a screw terminal block.

### Ground



### Indicator lamp

- Fastening OK: Green
- Alarm: Yellow
- Fastening NG: Red

### Torque Transducer Cable

### Resolver Cable

### NET Cable

This is used when multi spindle system is configured

### RS-232C

This is used to communicate with Management Software and it is also possible to connect with serial printer

### I/O

Input 12 Output 22  
The sync (NPN, -Common) or the source (PNP, +Common)

## External Dimensions

Unit : mm

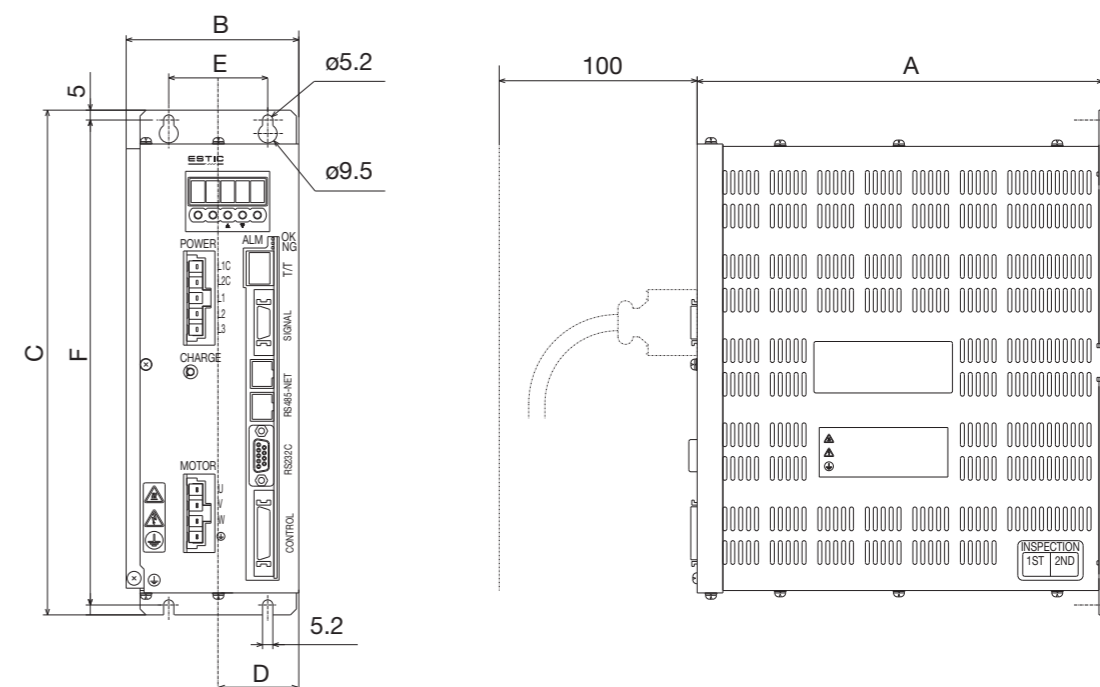

Model	A	B	C	D	E	F
ENRZ-AU50M-10	205	74	255	37	50	245
ENRZ-AU50M-20	205	87	255	41	50	245
ENRZ-AU50M-40	205	117	274	41	50	245
ENRZ-AU50M-2K	208	117	298	62	80	288

## General Specifications

Model	ENRZ-AU50M-10	ENRZ-AU50M-20	ENRZ-AU50M-40	ENRZ-AU50M-2K	ENRZ-AU50M-5K2
Motor type on tool unit	100W	200W	400W	2400W	5000W
Control power voltage	Single phase AC200~230V±10% 50/60Hz				
Main power voltage	Single phase AC200~230V±10% 50/60Hz		Three phase AC200~230V±10% 50/60Hz		
Operation environment	Free from corrosive/explosive gasses, dust/metal dust or oil mist.				
Operating temperature	0~55°C (No freezing)				
Operating humidity	35~90%RH (No condensing)				
Operation & Display Panel	7 Segment LED Display (5 letters x 1 line), 5 Function keys, Indicator lamps (OK/ALM/NG)				
Control Input	12 points, Photo Coupler Isolation (DC24V, Lead-in Current: 6mA/point) * The sync (NPN, -Common) or the source (PNP, +Common)				
Control Output	Photo MOS output 22 points (DC24V, max. 50mA/point) * The sync (NPN, -Common) or the source (PNP, +Common)				
Fastening Program	99 Programs				
NET Port	RS-485 x 2 ports (MAX. Connected Stations: 31 stations)				
COM Port	RS-232C x 1 port (Variable between: 9600bps - 115.2kbps)				
Recommended printer	Serial Printer EPSON VP-700				
Control Power Capacity	50VA				
Main Power Capacity (At Rated Operation)	0.4KVA	1.2KVA	1.7KVA	3.8KVA	8.0KVA
Dash Current when applying Control power	About 26 Ao-p (Converging Time: About 5ms)				
Dash Current when applying Main power	About 23 Ao-p (Converging Time: About 200ms)		About 6 Ao-p (Converging Time: About 400ms)		
Weight	2.5kg	3.2kg	3.4kg	3.5kg	5.6kg

### Various fastening strategies

Torque control, Angle control, Yield control and more are available as standard functions.

### Backward compatible

Previous tool models (ENRZ-TU\*\*\*-) and Encoder cable (ENRZ-CVEN-\*\*\*) are compatible with this controller.

### Speed boost function

Free run speed of Resover tool (ENRZ-TU\*\*\*R-) is significantly improved. [140% faster than the conventonal series]  
\* Tool model ENRZ-TU150R-S Free run speed is unchanged from AU50R system.

### Storage function

Fastening program: 99  
Fastening result: 5,115 records  
System error: 50 records

## Pre Fastening Monitoring

2 types of pre-fastening monitor functions are available. Seizing monitor and Section monitor. Seizing monitor is set by monitoring the angle once seat torque has been detected. The torque value is monitored when the angle changes by one degree or more and the monitor checks whether the torque value is within range of the set monitor min, and monitor max torque. Section monitor checks whether the torque value is within the range set with Monitor Max torque, and Monitor Min torque.

### 1. Seizing Monitor

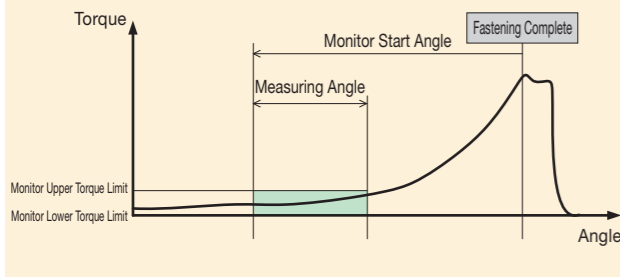

### 2. Section Monitor

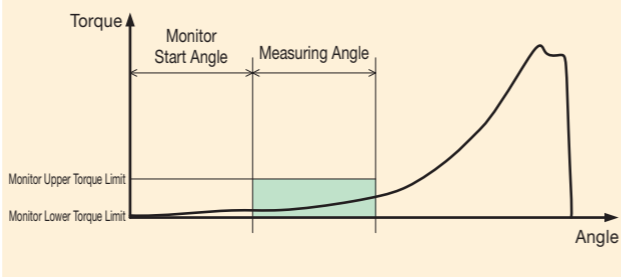

## Self Tapping Function

This function is used when a large torque is generated in the initial stage and this torque exceeds the seating torque as in the case of a tapping screw. After the start of pre fastening, the seating torque is not detected in the zone set with a Self Tap Interval, and peak hold of the torque detected in this zone is performed. It is checked whether the detected peak torque is within the range set with Self Tap Max Torque and Self Tap Min Torque. A judgment for the upper limit torque is always made during monitoring. A judgment for the lower limit torque is made after the completion of monitoring.

### 3. Self Tapping Monitor

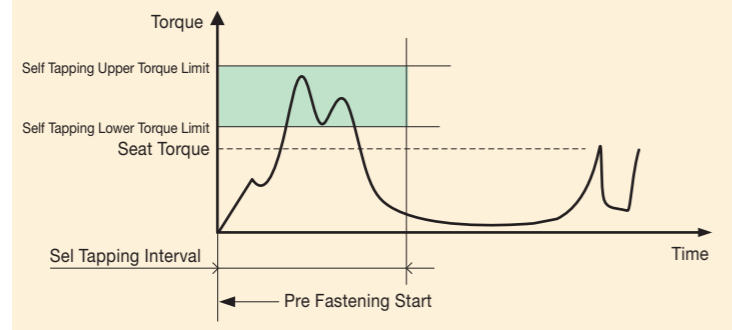

## Torque Rate Monitor Function

Fastening is performed while sampling the amount of torque change against a fastening angle of 1 deg and making a judgment. It is possible to divide the zone between the ANG start torque and a judgment is made. This function is used to monitor the condition of a workpiece and the condition of fastening.

A Back Rate Monitor function is also available. It works by calculating the torque rate after the completion of fastening, using the point obtained by returning the set angle as a start point and checking whether the result is within the range between the set upper limit and lower limit.

### 4. Torque Rate Monitor

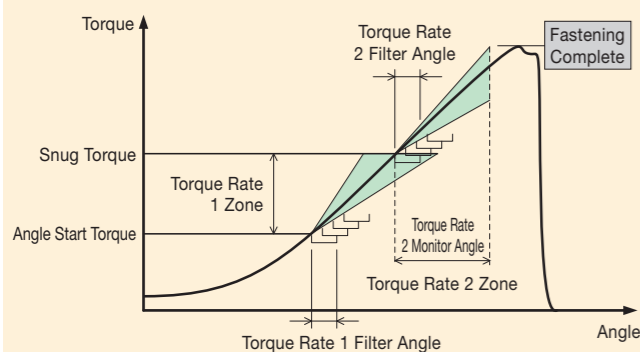

### 5. Back Rate Monitor

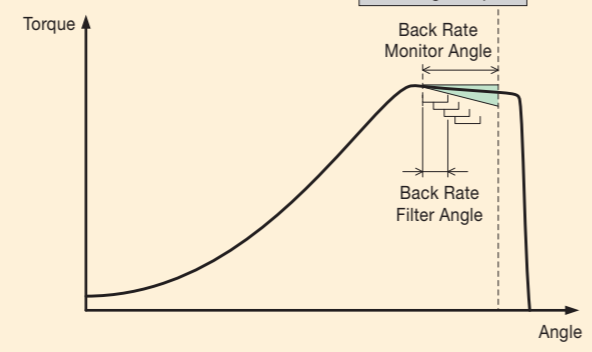

The Master Control Unit is capable of controlling a maximum of 31 AXIS Control Units.

Its advantages include Sequenced Fastening Program which makes PLC programming simple, Serial communication with PLC or Fieldbus communication with PLC which reduces wiring, and Multiple Work Groups management, to realize high performance fastening.



## Front Panel Wiring

### STATUS LED

Indicate the status of System error, communication with AXIS Unit, communication with PLC, PC.

### Key Switch

Switch monitor type, change and edit parameter setting on 7 segment LED display.

### RS-232C

Communicate with Management Software. Connection with a serial printer is also possible.

### PLC

Communicate with PLC by serial

### NET1

Connect with AXIS Control Unit or Press Control Unit.

### 7 Segment LED Display

Display Monitoring result, Parameter setting.

### ETHERNET

Connect with Management Software, Data Logger Software, ESTIC HMI through Ethernet (LAN).

### USB

Insert USB Flash Drive to export/import Parameter setting, Fastening/Pressing result.

### REMOTE I/O (Option)

Connect with OMRON Link Terminal.

### PC-USB

Connect with Management Software through USB cable.

### FIELDBUS (Option)

Connect with PLC by Fieldbus (DeviceNet, Ethernet/IP, Profibus-DP, Profinet, CC-Link).

### CF Card

Store System Program, Fastening Parameters, Fastening Results. All necessary files to run the system are stored here. If the Master Control Unit fails, System Recovery can be easily performed just by transferring the card.

### DIP SW

For settings

### EX-I/O (Option)

Input 16 Output 16

### CONTROL I/O

Input 6 Output 6  
The sync (NPN, -Common) or the source (PNP, +Common)

### POWER

AC100-230V

## ETHERNET PORT

Ethernet Port comes standard. It connects to LAN and allows for communication between 1 PC and multiple Master Control Units.

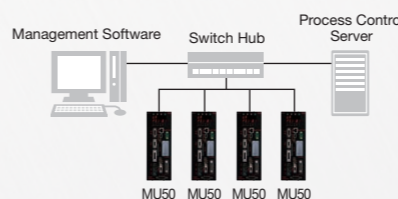

## FIELDBUS

DeviceNet, Ethernet/IP, Profibus-DP, Profinet, CC-Link are available as options.

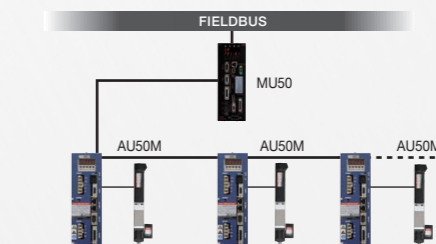

## DATA STORAGE

Fastening Program: 99  
Fastening result: 20,000 records  
Torque curve: 50 records  
System error: 200 records

## 1. Parallel operation of multi spindle fastening

The Master Control Unit is capable of creating up to 4 separate work groups. Each work group can be controlled separately as well as simultaneously using one Master Control Unit.

**Up to 31 nutrunners, and a maximum of 4 work groups can be controlled by one Master Control Unit.**

For example, one Master Control Unit can control 2 wheel tightening machines for both right and left. On other example, one Master Control Unit controls 4 nutrunners separately held by 4 robot arms.

Example: Wheel Tightening Machine

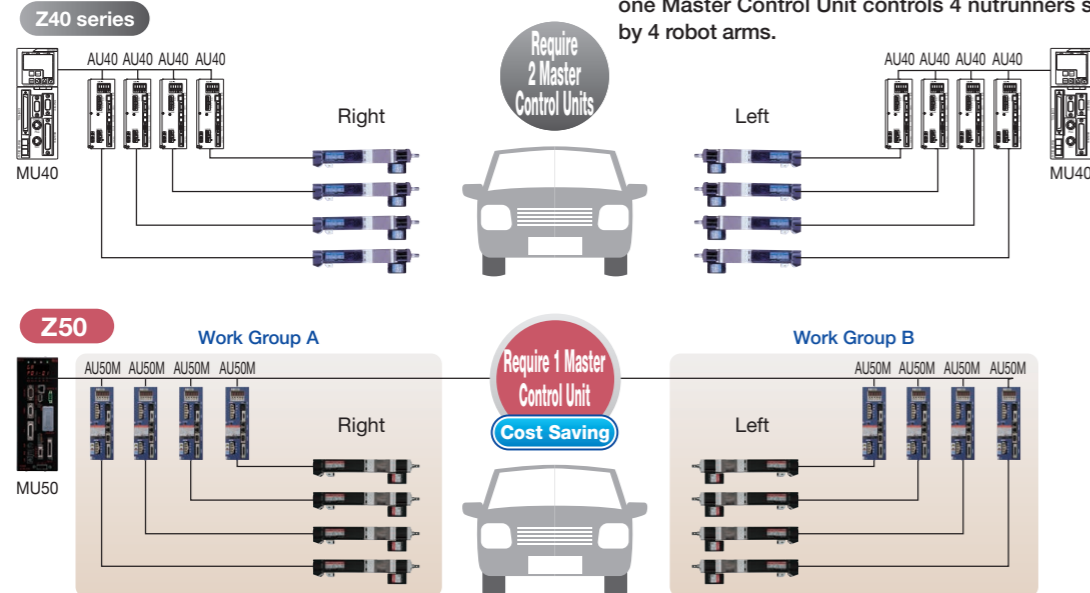

## 2. Sequenced Fastening Program

Each step of the fastening process such as Pre-fastening, Reversing, Fastening on multi-spindle can easily be programmed in one Program, with up to 20 steps.

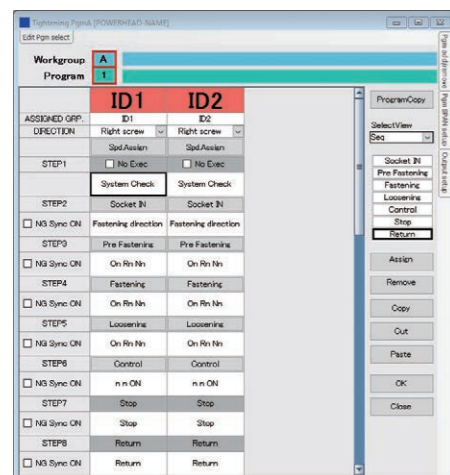

MU50 Fastening Program Menu

## 3. Simplified Logic Programming

Simplified logic such as A contact, B contact, AND, OR, Timer is available as a standard function, and it enables integration with the fastening system without a PLC.

● Program capacity: 500 steps

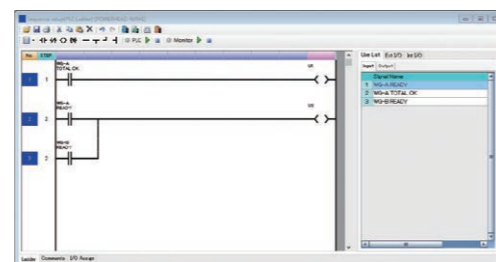

## 4. Connection with PLC by serial communication

Telegram is pre formatted for each PLC type through RS-232C or RS-422.

Applicable PLC

Manufacturer	Series
Mitsubishi Electric	MELSEC-A Series
	MELSEC-Q Series
Omron	SYSMAC-CS1 Series
	SYSMAC-CJ1 / CJ2 Series
Sharp	JW30 Series
	JW300 Series
JTEKT	TOYOPUC

## Master Control Unit Model

### ENRZ-MU50-N NN

Fieldbus Option

- Standard : N : Without Fieldbus
- Option : D : DeviceNet
- P : Profibus-DP
- C : CC-Link
- E : Ethernet/IP
- T : Profinet

I/O Option

- Standard : NN : Without Extend I/O and Remote I/O
- Option : EN : With Extend I/O Without Remote I/O
- ER : With Extend I/O and Remote I/O

## Master Control Unit External Dimensions

Unit : mm

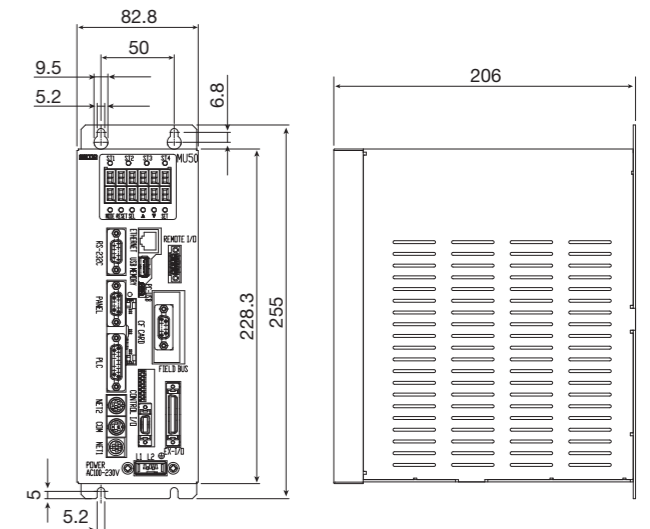

## General Specifications

Input voltage	AC100V~230V±10% (50/60Hz) 80W
Operation environment	Free from corrosive/explosive gasses, dust/metal dust or oil mist.
Operating temperature	0~45°C(No freezing)
Operating humidity	90%RH or less(No condensing)
Operation & Display Panel	7 Segment LED Display (6 letters x 2 lines), 6 Function keys, Indicator lamps (ST1/ST2/ST3/ST4)
Control Input/Output	CONTROL I/O, EX-I/O (Option) , REMOTE I/O (Option)
Max. number of spindle connection	31 spindle (AU50: 31, SPU50: 10, Total max. 31)
Fastening Program	99 Programs
Communication Port	RS-232C (Management Software, Serial Printer) COM connector (RS-422: Available in the future)
	PANEL (RS-422 port for HMI) ETHERNET (10/100BASE-T)
	PLC (RS-232C/RS-422 for PLC Serial connection) PC-USB (USB port for Management Software)
	NET1 (RS485 for connecting with Local unit) FIELDBUS (DeviceNet, Profibus, Profinet, Ethernet/IP, CC-Link)
Storage function	Fastening program, Press Program, System Parameter, I/O Assign, Fastening Result Item Assign, System Error, Fastening/Press Result
Number of record	Fastening/Press Result History: Max. 20,000 records
	Torque/Press Curve History: Max. 50 records System Error History: Max. 200 records
External Storage	Export/Import Fastening/Press Result History file, Fastening/Press/System Parameter file to USB Flash Drive
Others	I/O Assign function, Result Item Assign function, Sinplified Logic Program function

## Control Input/Output

Control I/O	Input	Photo coupler isolation, 24VDC 7mA, 6 points Either of sync (-common) and source (+common) is possible
	Output	Photo MOS output, 24VDC 50mA, 6 points Either of sync (-common) and source (+common) is possible
EX-I/O	Input	Photo coupler isolation, 24VDC 7mA, 16 points Either of sync (-common) and source (+common) is possible
	Output	Photo MOS output, 24VDC 50mA, 16 points Either of sync (-common) and source (+common) is possible
REMOTE I/O	Input	Link terminal by OMRON, 16 points, Transmission delay time: Standard type (OMRON model B7A-T6D2)
	Output	Link terminal by OMRON, 16 points, Transmission delay time: Standard type (OMRON model B7A-R6A52)
	Transmit distance	500m max. (varying depending on wiring configuration)

## Management Software: ENRZ-PC50

The Z50 management software to be installed on a PC. Language: Japanese, English  
 Compatible OS: Windows10, Windows8/8.1, Windows7 SP1, WindowsVista Sp1.2 32bit, WindowsXP SP3 32bit

## Features

### 1. Parameter

- AXIS/Press Control Unit Parameter
- Master Control Unit System Parameter
- Fastening/Press Setting
- Simplified Logic Program



Master Control Unit Setting



Sequenced Fastening Program



Fastening Easy Setting

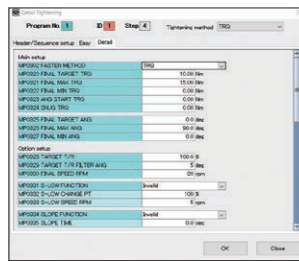

Fastening Detailed Setting

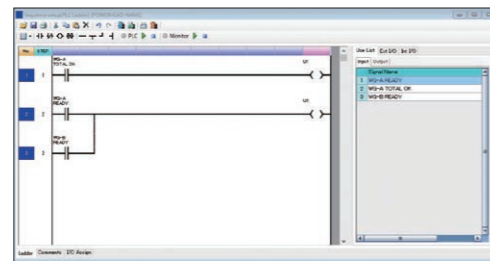

Logic Program

### 2. Result Monitor & History

- Fastening/Press Result Monitor & History
- System Error History
- Torque/Load Curve Monitor & History

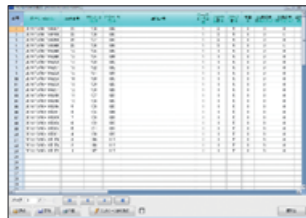

Fastening Result History

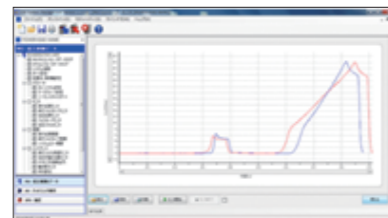

Torque Curve History

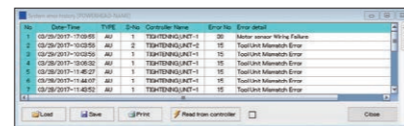

System Error History

### 3. Maintenance

- Torque, Angle and CAL Monitor
- I/O Monitor
- AXIS Bypass Monitor

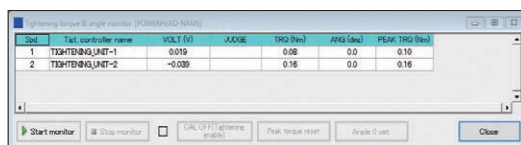

Torque & Angle Monitor

### 4. Assign

- I/O Assign
- PLC I/O Assign
- FIELDBUS I/O Assign
- Fastening Result Item Assign

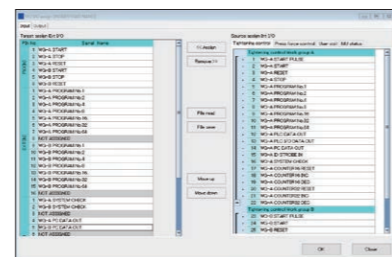

I/O Assign

## Display Unit: ENRZ-DP50

HMI unit for Master Control Unit  
 User friendly menu for easy operation

ENRZ-DP50E: Ethernet connection  
 ENRZ-DP50S: Serial connection

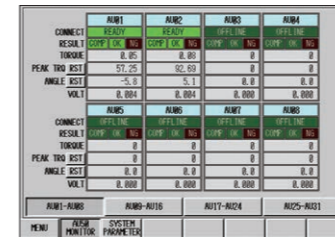

AXIS Unit Monitor

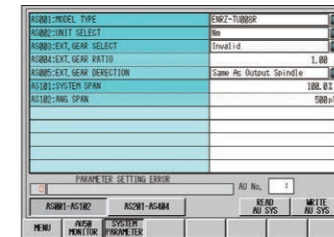

AXIS Unit System Setting



Fastening Parameter Edit

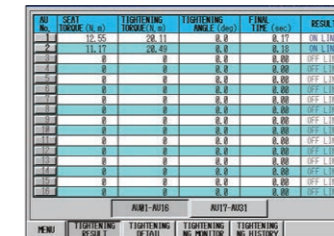

Fastening Result Monitor

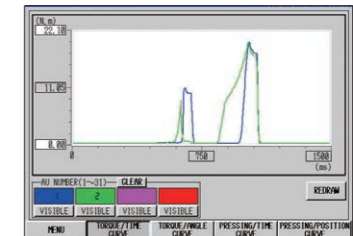

Torque Curve Monitor

## Data Logger Software: ESW-DL

Software to gather and store fastening results for quality analysis

### System Configuration

Data Logger Software is capable of connecting with the Z50 series Fixtured Nutrunner, Servo Press and also Handy2000Lite series Handheld Tool.  
 Multiple spindles can be handled with a single software through LAN network.

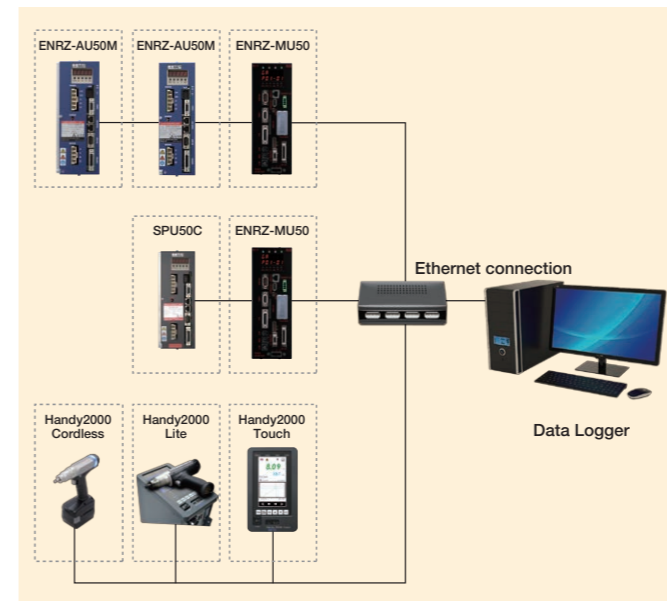

### Fastening Result Logging

Master Control Unit outputs result data after each fastening and data is stored in Data Logger Software.

### Search & View function

Search and view function helps users find the necessary data stored in the Data Logger Database.



Stored data can be output by CSV format daily at preset time.

## System Configuration

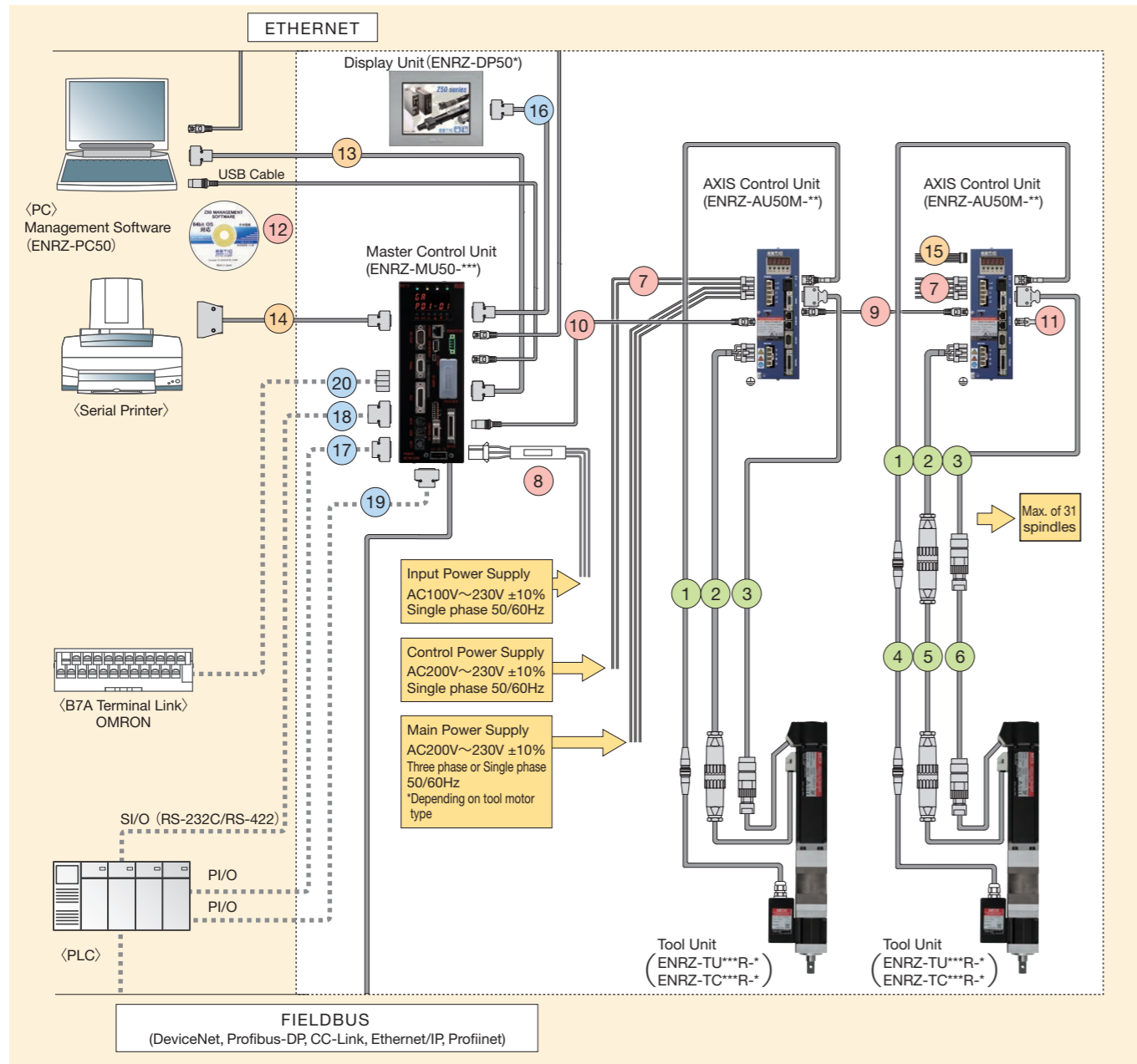

## Steps to select Master Control System



Example) This the example when 2 spindles of 10Nm rated torque model are connected by Profibus

Item	Model	Quantity
Tool Unit	ENRZ-TU001R-S	2
AXIS Control Unit	ENRZ-AU50M-10	2
Master Control Unit	ENRZ-MU50-TNN	1
Torque Transducer Cable	ENRZ-CVTN2-050	2
Motor Cable	ENRZ-CVMN2-050	2
Resolver Cable	ENRZ-CVRN-050	2
NET Cable	ENRZ-CVVK3M-010	1
NET Cable	ENRZ-CVVK2A-010	1
Termination Resistor	ENRZ-CVST3	1
Management Software	ENRZ-PC50	1
Serial Communication Cable	ENRZ-CVSR-050	1

Table 1 : Tool Unit/AXIS Control Unit combination

Tool Unit model	Applicable Torque Range (Nm)	Corresponding AXIS Control Unit
ENRZ-TU0R5R-S	0.5-4.5	ENRZ-AU50M-10
ENRZ-TU001R-*	1-9	ENRZ-AU50M-20
ENRZ-TU002R-*	2-18	ENRZ-AU50M-10
ENRZ-TU003R-*	3-27	ENRZ-AU50M-20
ENRZ-TC004R-*	4-36	ENRZ-AU50M-20
ENRZ-TU004R-S	4-36	ENRZ-AU50M-20
ENRZ-TU008R-*	8-72	
ENRZ-TU013R-*	13-117	
ENRZ-TU020R-*	20-180	
ENRZ-TU040R-*	40-360	
ENRZ-TU050R-S	50-450	ENRZ-AU50M-5K2
ENRZ-TU060R-S	60-540	ENRZ-AU50M-40
ENRZ-TU080R-S	80-720	
ENRZ-TU120R-S	120-1080	ENRZ-AU50M-5K2
ENRZ-TU150R-S	150-1350	ENRZ-AU50M-2K
ENRZ-TU300R-S	300-2700	ENRZ-AU50M-5K2

\* is replaced with the symbol of S: Straight type, O: Offset type  
Please see the system configuration of tool model ENRZ-TU050R-S, TU120R-S, TU150R-S, TU300R-S on page 25 - 26.

Table 2 : Master Control Unit

Model	Option					I/O	
	DeviceNet	Profibus-DP	CC-Link	EtherNet/IP	Profinet	EX-I/O	REMOTE I/O
ENRZ-MU50-NNN							
ENRZ-MU50-NEN						●	
ENRZ-MU50-NER						●	●
ENRZ-MU50-DNN	●						
ENRZ-MU50-DEN	●					●	
ENRZ-MU50-DER	●					●	●
ENRZ-MU50-PNN		●					
ENRZ-MU50-PEN		●					
ENRZ-MU50-PER		●				●	●
ENRZ-MU50-CNN			●				
ENRZ-MU50-CEN			●			●	
ENRZ-MU50-CER			●			●	●
ENRZ-MU50-ENN				●			
ENRZ-MU50-EEN				●		●	
ENRZ-MU50-EER				●		●	●
ENRZ-MU50-TNN					●		
ENRZ-MU50-TEN					●	●	
ENRZ-MU50-TER					●	●	●

Table 3 : Cables and Accessories

No.	Item	Specification	Model
1	Torque Transducer Cable	5[m]	ENRZ-CVTN2-050
		10[m]	ENRZ-CVTN2-100
		15[m]	ENRZ-CVTN2-150
		20[m]	ENRZ-CVTN2-200
2	Motor Cable	5[m]	ENRZ-CVMN2-050
		10[m]	ENRZ-CVMN2-100
		15[m]	ENRZ-CVMN2-150
		20[m]	ENRZ-CVMN2-200
3	Resolver Cable	5[m]	ENRZ-CVRN-050
		10[m]	ENRZ-CVRN-100
		15[m]	ENRZ-CVRN-150
4	Torque Transducer Relay Cable	3[m]	ENRZ-CVTN-030
		6[m]	ENRZ-CVTN-060
		10[m]	ENRZ-CVTN-100
		15[m]	ENRZ-CVTN-150
5	Motor Relay Cable	3[m]	ENRZ-CVMP-030
		6[m]	ENRZ-CVMP-060
		10[m]	ENRZ-CVMP-100
		15[m]	ENRZ-CVMP-150
6	Resolver Relay Cable	3[m]	ENRZ-CVRP-030
		6[m]	ENRZ-CVRP-060
		10[m]	ENRZ-CVRP-100
7	AXIS Control Unit Power Cable *1	3[m]	ENRZ-CVDC2-030
		3[m]	ENRZ-CVDC3-030
8	Master Control Unit Power Cable *2	3[m]	ENRZ-CVDC3-030

No.	Item	Specification	Model
9	NET Cable (AU50M⇔AU50M)	0.2[m]	ENRZ-CVVK2A-002
		1[m]	ENRZ-CVVK2A-010
		2[m]	ENRZ-CVVK2A-020
10	NET Cable (MU50⇔AU50M)	0.3[m]	ENRZ-CVVK3M-003
		1[m]	ENRZ-CVVK3M-010
		3[m]	ENRZ-CVVK3M-030
		10[m]	ENRZ-CVVK3M-100
11	Termination Resistor *3	-	ENRZ-CVST3
12	Management Software	English/ Japanese	ENRZ-PC50
13	Serial Communication Cable	1.5[m]	ENRZ-CVSR-015
		5[m]	ENRZ-CVSR-050
		10[m]	ENRZ-CVSR-100
14	Serial Printer Cable	3[m]	ENRZ-CVSP-030
		5[m]	ENRZ-CVSP-050
		10[m]	ENRZ-CVSP-100
15	Check Connector Cable	3[m]	ENRZ-CVCK-030
16	Display Unit Serial Connection Cable	3[m]	ENRZ-CVDP2-030
		5[m]	ENRZ-CVDP2-050
		10[m]	ENRZ-CVDP2-100
17	Control Connector	-	ENRZ-CN14-CR
18	PLC Connector	-	ENRZ-CN15-PL
19	EX Connector	-	ENRZ-CN36-EX
20	Remote I/O Connector	-	EH2-FCN04-RM

\*1 Included with AXIS Control Unit  
\*2 Included with Master Control Unit  
\*3 Last AXIS Control Unit on the system needs 1 piece of Termination Resistor

## AXIS Control System (Except for ENRZ-TU150R-S)

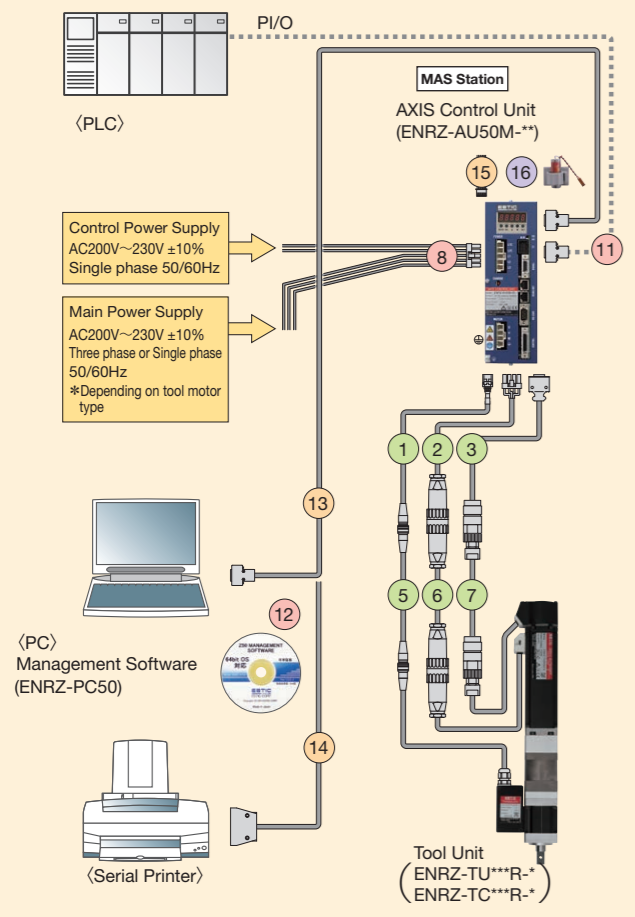

## AXIS Control System (ENRZ-TU150R-S)

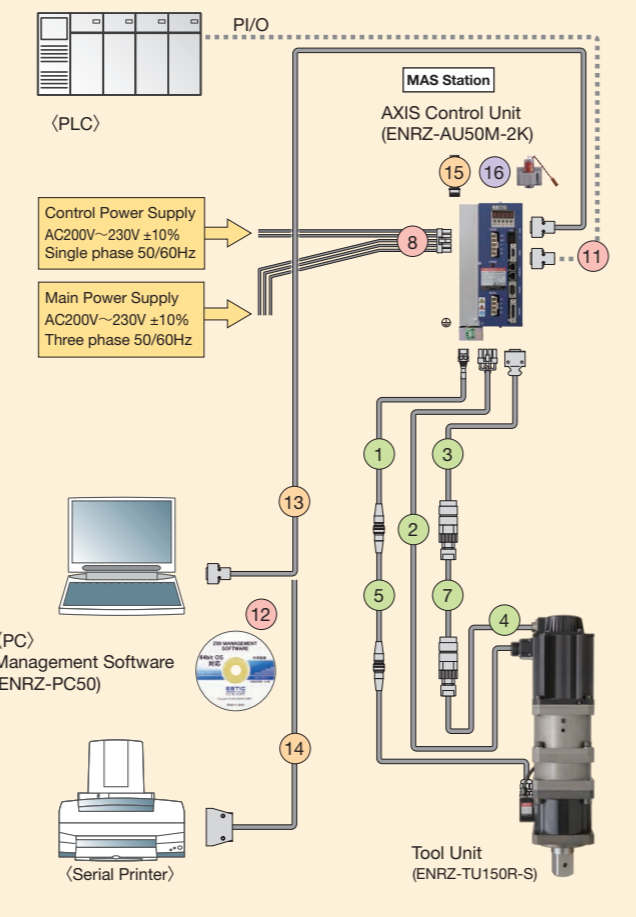

## AXIS Control Multi Spindle System (Except for ENRZ-TU150R-S)

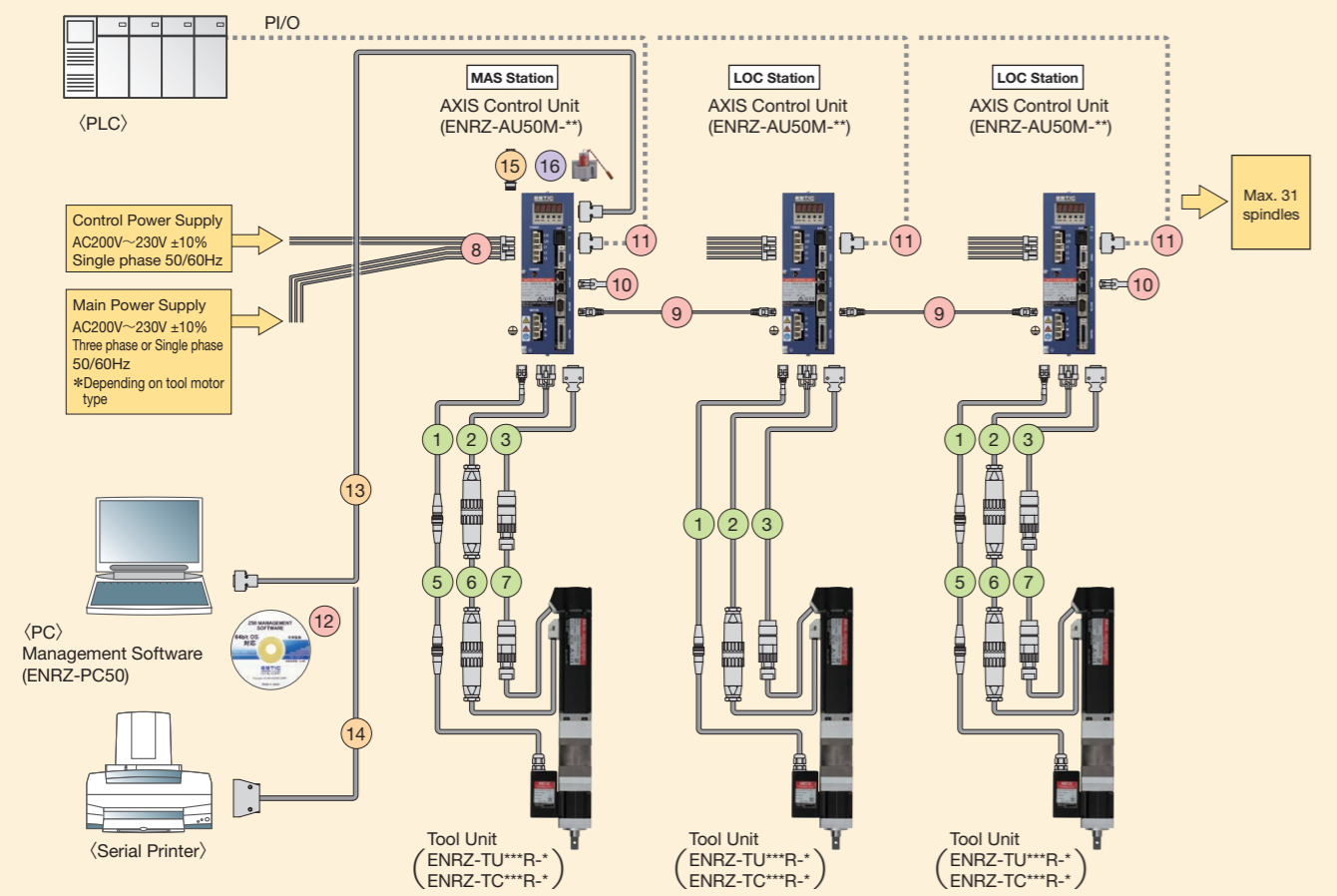

## Steps to select Master Control System

Select Tool Unit model and AXIS Control Unit model [see table 1]

Select Motor Cable, Torque Transducer Cable, Resolver Cable [see table 2]

Select accessories [see table 2]

### Example 1) Required for 10Nm-rated torque tool unit

Item	Model	Quantity
Tool Unit	ENRZ-TU001R-S	1
AXIS Control Unit	ENRZ-AU50M-10	1
Torque Transducer Cable	ENRZ-CVTN2-050	1
Motor Cable	ENRZ-CVMN2-050	1
Resolver Cable	ENRZ-CVRN-050	1
Battery	ENRZ-BATT	1
Control Connector	ENRZ-CNAU	1
Management Software	ENRZ-PC50	1
Serial Communication Cable	ENRZ-CVSR-050	1

### Example 3) Required for 3, 10Nm-rated torque spindle tool units

Item	Model	Quantity
Tool Unit	ENRZ-TU001R-S	3
AXIS Control Unit	ENRZ-AU50M-10	3
Torque Transducer Cable	ENRZ-CVTN2-050	3
Motor Cable	ENRZ-CVMN2-050	3
Resolver Cable	ENRZ-CVRN-050	3
Battery	ENRZ-BATT	1
NET Cable	ENRZ-CVKN2A-010	2
Termination Resistor	ENRZ-CVST3	2
Control Connector	ENRZ-CNAU	3
Management Software	ENRZ-PC50	1
Serial Communication Cable	ENRZ-CVSR-050	1

### Example 2) Required for 1500Nm-rated torque tool unit

Item	Model	Quantity
Tool Unit	ENRZ-TU150R-S	1
AXIS Control Unit	ENRZ-AU50M-2K	1
Torque Transducer Cable	ENRZ-CVTN2-050	1
Motor Cable	ENRZ-CVMN3-050	1
Resolver Cable	ENRZ-CVRN-050	1
Battery	ENRZ-BATT	1
Control Connector	ENRZ-CNAU	1
Management Software	ENRZ-PC50	1
Serial Communication Cable	ENRZ-CVSR-050	1

Table 1 : Tool Unit/AXIS Control Unit combination

Tool Unit model	Applicable Torque Range (Nm)	Corresponding AXIS Control Unit
ENRZ-TU0R5R-S	0.5-4.5	ENRZ-AU50M-10
ENRZ-TU001R-*	1-9	
ENRZ-TC002R-*	2-18	ENRZ-AU50M-20
ENRZ-TU003R-*	3-27	ENRZ-AU50M-10
ENRZ-TC004R-*	4-36	
ENRZ-TU004R-S	4-36	ENRZ-AU50M-20
ENRZ-TU008R-*	8-72	

Tool Unit model	Applicable Torque Range (Nm)	Corresponding AXIS Control Unit
ENRZ-TU013R-*	13-117	ENRZ-AU50M-20
ENRZ-TU020R-*	20-180	
ENRZ-TU040R-*	40-360	ENRZ-AU50M-5K2
ENRZ-TU050R-S	50-450	
ENRZ-TU060R-S	60-540	ENRZ-AU50M-40
ENRZ-TU080R-S	80-720	
ENRZ-TU120R-S	120-1080	ENRZ-AU50M-5K2
ENRZ-TU150R-S	150-1350	ENRZ-AU50M-2K
ENRZ-TU300R-S	300-2700	ENRZ-AU50M-5K2

\* is replaced with the symbol of S: Straight type, O: Offset type

Table 2 : Cables and Accessories

No.	Item	Specification	Model
1	Torque Transducer Cable	5[m]	ENRZ-CVTN2-050
		10[m]	ENRZ-CVTN2-100
		15[m]	ENRZ-CVTN2-150
		20[m]	ENRZ-CVTN2-200
2	Motor Cable	5[m]	ENRZ-CVMN2-050
		10[m]	ENRZ-CVMN2-100
		15[m]	ENRZ-CVMN2-150
		20[m]	ENRZ-CVMN2-200
		5[m]	ENRZ-CVMN3-050
		10[m]	ENRZ-CVMN3-100
3	Resolver Cable	5[m]	ENRZ-CVRN-050
		10[m]	ENRZ-CVRN-100
		15[m]	ENRZ-CVRN-150
		20[m]	ENRZ-CVRN-200
4	Resolver Conversion Cable (For ENRZ-TU150R-S only) *1	1[m]	ENRZ-CVREX-010
5	Torque Transducer Relay Cable	3[m]	ENRZ-CVTN-030
		6[m]	ENRZ-CVTN-060
		10[m]	ENRZ-CVTN-100
		15[m]	ENRZ-CVTN-150
		3[m]	ENRZ-CVMP-030
6	Motor Relay Cable	6[m]	ENRZ-CVMP-060
		10[m]	ENRZ-CVMP-100
		15[m]	ENRZ-CVMP-150
		3[m]	ENRZ-CVMP7-030
		6[m]	ENRZ-CVMP7-060
7	Resolver Relay Cable	3[m]	ENRZ-CVSR-015
		5[m]	ENRZ-CVSR-050
		10[m]	ENRZ-CVSR-100
		15[m]	ENRZ-CVSR-150
8	AXIS Control Unit Power Cable *2	3[m]	ENRZ-CVDC2-030
		0.2[m]	ENRZ-CVKN2A-002
		1[m]	ENRZ-CVKN2A-010
		2[m]	ENRZ-CVKN2A-020
9	NET Cable (AU50M ↔ AU50M)	-	ENRZ-CVST3
10	Termination Resistor *3	-	ENRZ-CVST3
11	Control Connector	-	ENRZ-CNAU
12	Management Software	English/ Japanese	ENRZ-PC50
13	Serial Communication Cable	1.5[m]	ENRZ-CVSR-015
		5[m]	ENRZ-CVSR-050
		10[m]	ENRZ-CVSR-100
14	Serial Printer Cable	3[m]	ENRZ-CVSP-030
		5[m]	ENRZ-CVSP-050
		10[m]	ENRZ-CVSP-100
15	Check Connector Cable	3[m]	ENRZ-CVCK-030
16	Battery *4	-	ENRZ-BATT

\*1 Included with ENRZ-TU150R-S

\*2 Included with AXIS Control Unit

\*3 One each for MAS Station and last unit of LOC Station required when Multi Spindle System is configured.

\*4 MAS Station needs 1 piece of battery

## Allowable load on the anvil

Load applied on the anvil (except fastening torque) is required to design within the value below.

Unit: N (kgf)

Model	Thrust/Radial load
ENRZ-TU0R5R-S	49 (5)
ENRZ-TU001R-S	98 (10)
ENRZ-TU001R-O	98 (10)
ENRZ-TC002R-S	98 (10)
ENRZ-TC002R-O	98 (10)
ENRZ-TU003R-S	98 (10)
ENRZ-TU003R-O	98 (10)
ENRZ-TC004R-S	98 (10)
ENRZ-TC004R-O	98 (10)
ENRZ-TU004R-S	98 (10)
ENRZ-TU008R-S	196 (20)
ENRZ-TU008R-O	147 (15)
ENRZ-TU013R-S	196 (20)
ENRZ-TU013R-O	147 (15)
ENRZ-TU020R-S	294 (30)
ENRZ-TU020R-O	147 (15)
ENRZ-TU040R-S	294 (30)
ENRZ-TU040R-O	147 (15)
ENRZ-TU050R-S	294 (30)
ENRZ-TU060R-S	294 (30)
ENRZ-TU080R-S	294 (30)
ENRZ-TU120R-S	294 (30)
ENRZ-TU150R-S	588 (60)
ENRZ-TU300R-S	588 (60)

Thrust load and radial load is same.

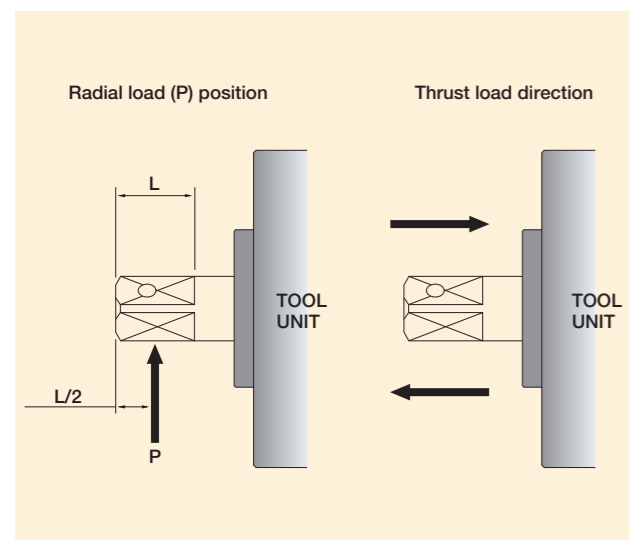

## Installation of Tool Unit

- 1) As this Nutrunner system has a mechanism for detecting the torque reaction from the rotation torque of the output shaft to the unit body, please be aware that the tool unit body should not have mechanical interference.

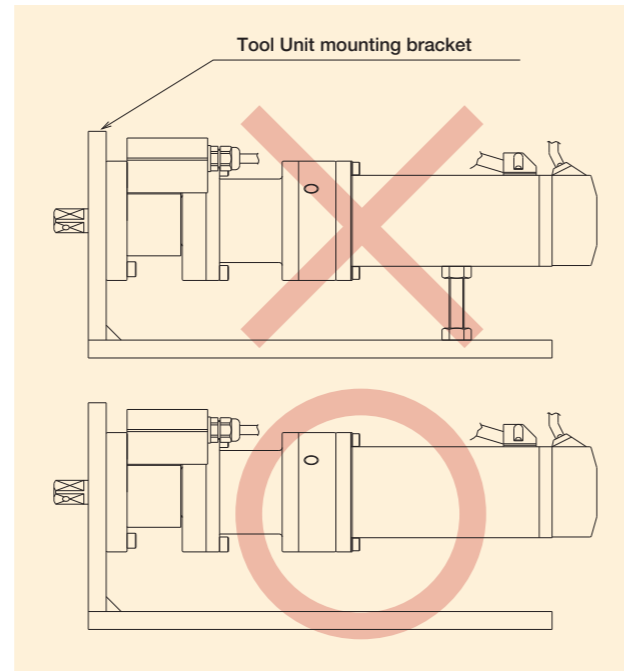

- 2) When the tool unit mounting bracket or the work jig etc., moves because of the torque reaction force generated at the time of fastening, this causes scatter of the fastening accuracy. When the center deviation is large, an excessive force acts onto the shaft, and this can cause shaft breakage. Special care is required in regard to insufficient strength of the mounting bracket etc., and in regard to center deviation.
- 3) When the pitch between shafts is small, such as in a multishaft installation, take care to prevent interference between tool units. (Normal torque measuring is not possible.)
- 4) When dry bushings, etc., are used for bearings downstream from the Nutrunner output shaft, torque is lost because of the dry bushing and it is to be feared that there will be a difference between the Nutrunner display value and the actual fastening torque may differ. Use of dry bushings should be avoided as much as possible.
- 5) When the shaft pitch is narrow because of the use of multiple spindles, gears, etc., inserted after the Nutrunner output shaft to correspond with the narrow space between shafts, the Nutrunner display value and the actual fastening torque may differ because of the influence on gear efficiency, pulsations, etc., Use of constant speed joints is recommended when the shaft pitch is to be reduced.

## Installation of Control Unit

- 1) Always connect the protective ground terminal of the control unit and the protective ground terminal of the control panel to prevent electric shock. Use one-point class 3 grounding (100 Ω or lower).
- 2) Do not use the same power supply for control I/O control and electromagnetic contactors etc. This can cause erroneous operation and system errors because of noise.
- 3) Leave a free space of 100 mm or more above the top and underneath the control unit and do not inhibit air circulation.
- 4) Install a heat exchanger or a panel cooler for uniform temperature in the control panel.
- 5) For proper heat dissipation, it is recommended to install units with a space of at least 10 mm between units.

### Installation of AXIS Control Unit

(ENRZ-AU50M-10, ENRZ-AU50M-20, ENRZ-AU50M-40)

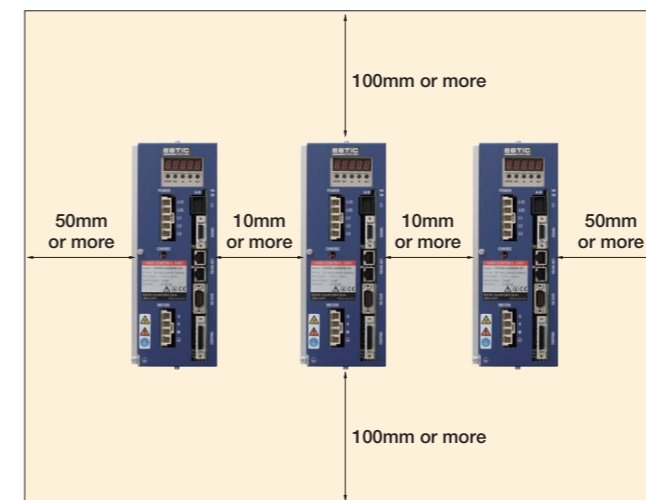

(ENRZ-AU50M-2K)

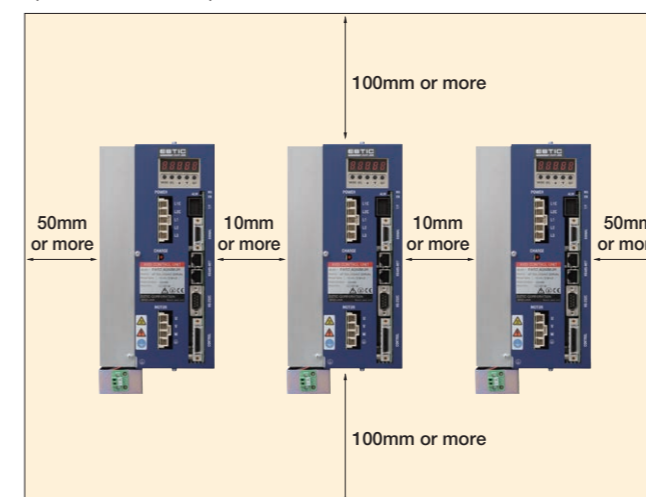

## Caution for cabling

- 1) Wiring in a flexible tube or wiring on a cable conveyor is recommended for the Nutrunners moving parts. To prevent wire breaks, pay attention to the following points for routing of cable bundles.

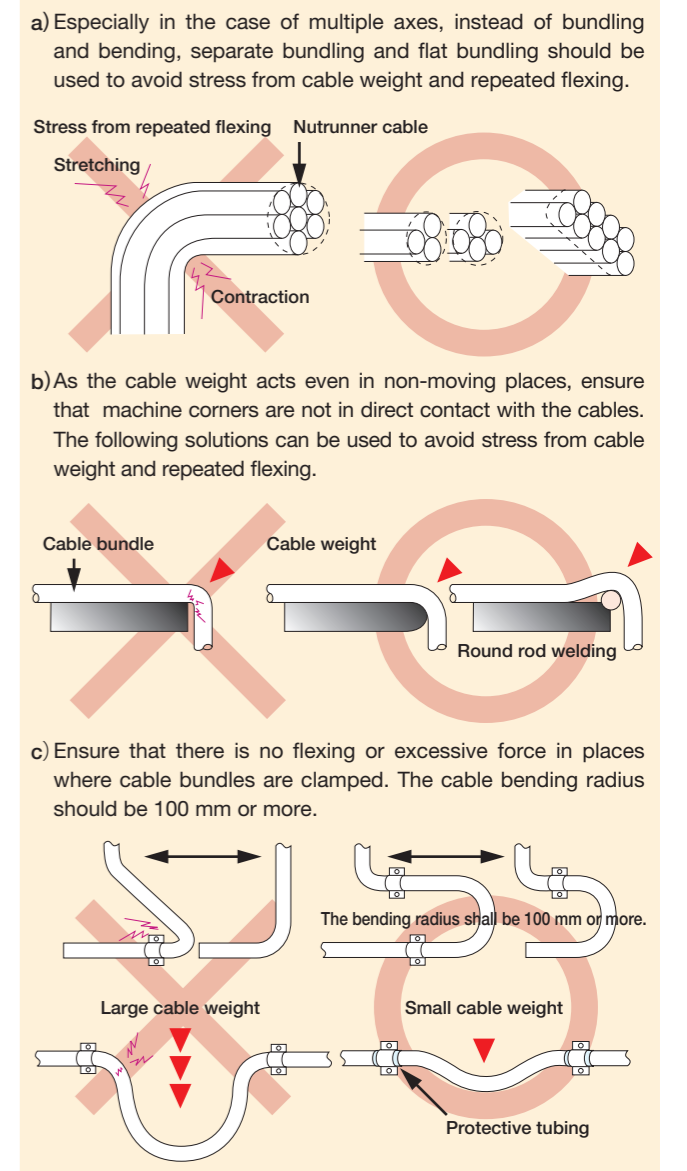

- 2) The wiring method for transducer, encoder, and motor cables should make it so that no forces act onto the connector part.
- 3) When Nutrunner cables are laid within the same flexible conduit (in case of multiple units etc.), the distance should be kept as short as possible and laying in the same flexible conduit with power cables should be avoided.
- 4) Basically, it is recommended to wire transducer and encoder cables separately from motor cables. (Distance between cables: 30 cm or more)

## Fastening Machine for Engine Assembly

Cam Cap Assembly Machine



Bearing Cap Press & Fastening Machine



## Fastening Machine for Transmission Assembly

Oil Pan Fastening Machine with Automatic Bolt Feeder



Side Cover Fastening Machine with Automatic Bolt Feeder



Conrod Assembly Machine

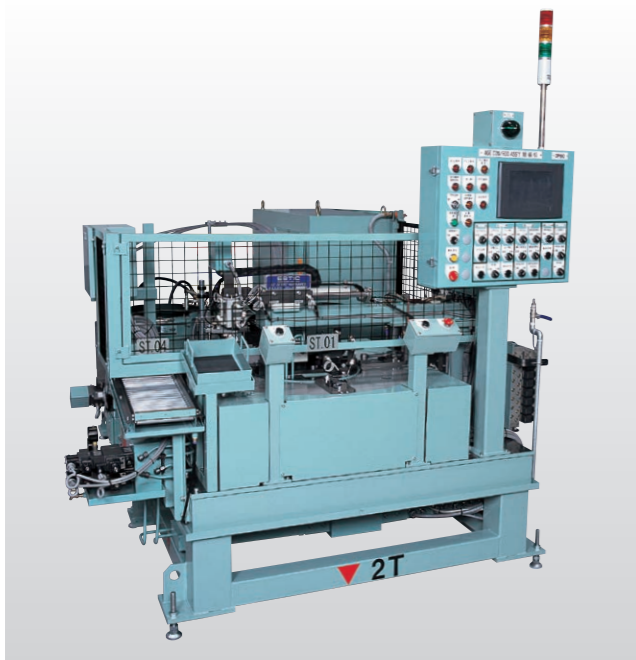

Cylinder Head Assembly Machine



## Fastening Machine for Vehicle Body Assembly

Front Suspension Frame Re-tightening Machine

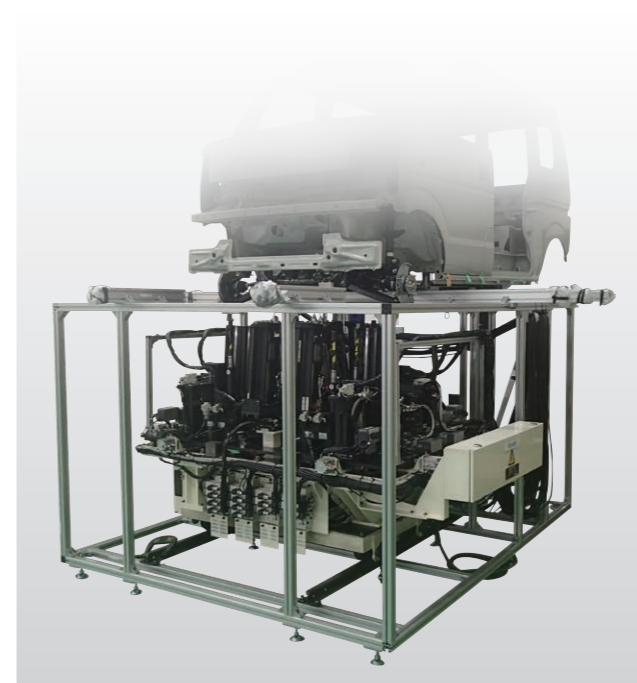

Front Strut Assembly Machine

